

This voltage is across the emitter resistance, which is now 1 k $\Omega$ . Therefore, the emitter current is 4.3 V divided by 1 k $\Omega$ , or:

$$I_E = \frac{4.3 \text{ V}}{1 \text{ k}\Omega} = 4.3 \text{ mA}$$

The collector current is approximately equal to 4.3 mA. When this current flows through the collector resistance (now 2 k $\Omega$ ), it produces a voltage of:

$$I_C R_C = (4.3 \text{ mA})(2 \text{ k}\Omega) = 8.6 \text{ V}$$

When you subtract this voltage from the collector supply voltage, you get:

$$V_C = 15 \text{ V} - 8.6 \text{ V} = 6.4 \text{ V}$$

This voltage value is very close to the value measured by the MultiSim meter. Remember, this is the voltage between the collector and ground. This is what you would measure when troubleshooting.

Unless you have a voltmeter with a high input resistance and a floating ground lead, you should not attempt to connect a voltmeter directly between the collector and the emitter because this may short the emitter to ground. If you want to know the value of  $V_{CE}$ , you should measure the collector-to-ground voltage, then measure the emitter-to-ground voltage, and subtract the two. In this case:

$$V_{CE} = 6.4 \text{ V} - 4.3 \text{ V} = 2.1 \text{ V}$$

**PRACTICE PROBLEM 7-9**  **MultiSim** Decrease the base supply voltage of Fig. 7-11 to 3 V. Predict and measure the new value of  $V_{CE}$ .

## 7-7 LED Drivers

You have learned that base-biased circuits set up a fixed value of base current, and emitter-biased circuits set up a fixed value of emitter current. Because of the problem with current gain, base-biased circuits are normally designed to switch between saturation and cutoff, whereas emitter-biased circuits are usually designed to operate in the active region.

In this section, we discuss two circuits that can be used as LED drivers. The first circuit uses base bias, and the second circuit uses emitter bias. This will give you a chance to see how each circuit performs in the same application.

### Base-Biased LED Driver

The base current is zero in Fig. 7-12a, which means that the transistor is at cutoff. When the switch of Fig. 7-12a closes, the transistor goes into hard saturation. Visualize a short between the collector-emitter terminals. Then the collector supply voltage (15 V) appears across the series connection of the 1.5 k $\Omega$  and the LED. If we ignore the voltage drop across the LED, the collector current is ideally 10 mA. But if we allow 2 V across the LED, then there is 13 V across the 1.5 k $\Omega$ , and the collector current is 13 V divided by 1.5 k $\Omega$ , or 8.67 mA.

Figure 7-12 (a) Base-biased; (b) emitter-biased.

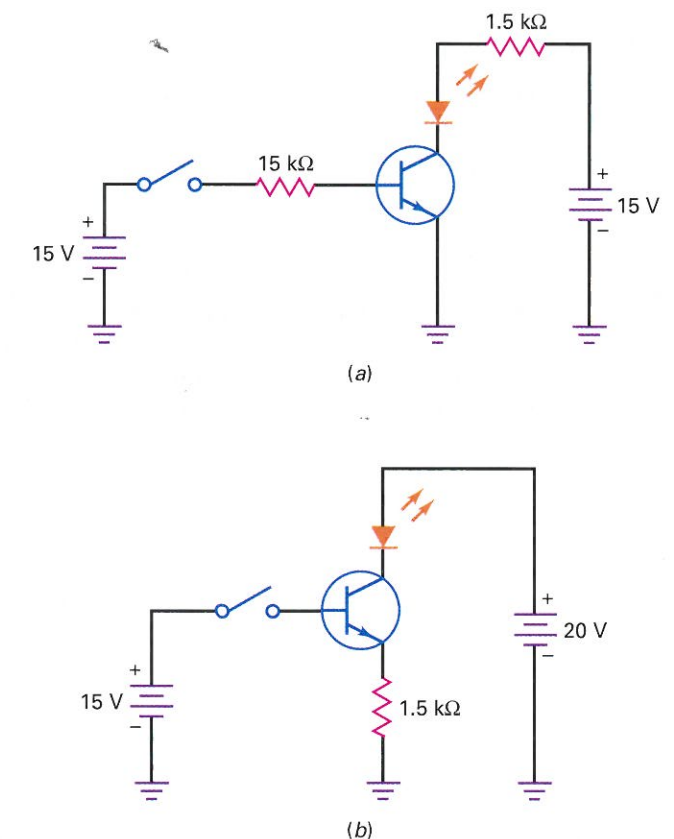

There is nothing wrong with this circuit. It makes a fine LED driver because it is designed for hard saturation, where the current gain doesn't matter. If you want to change the LED current in this circuit, you can change either the collector resistance or the collector supply voltage. The base resistance is made 10 times larger than the collector resistance because we want hard saturation when the switch is closed.

### Emitter-Biased LED Driver

The emitter current is zero in Fig. 7-12b, which means that the transistor is at cutoff. When the switch of Fig. 7-12b closes, the transistor goes into the active region. Ideally, the emitter voltage is 15 V. This means that we get an emitter current of 10 mA. This time, the LED voltage drop has no effect. It doesn't matter whether the exact LED voltage is 1.8, 2, or 2.5 V. This is an advantage of the emitter-biased design over the base-biased design. The LED current is independent of the LED voltage. Another advantage is that the circuit doesn't require a collector resistor.

The emitter-biased circuit of Fig. 7-12b operates in the active region when the switch is closed. To change the LED current, you can change the base supply voltage or the emitter resistance. For instance, if you vary the base supply voltage, the LED current varies in direct proportion.