

# Physics 225

Fall 2014

## Problem Set # 6

- 1) Greezy works in a factory because he does not make enough money from The Charming Beggars. He is pushing a very large crate of 50 kg across the floor at a constant velocity with a force of 200 N. He is pushing on the crate upwards at an angle of  $20^\circ$ . See diagram. (a) What is the coefficient of kinetic friction between the ground and the crate? (b) Greezy increases his force to 400 N. What is the acceleration of the crate?

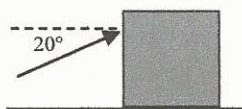

- 2) Two masses,  $m_1 = 10$  kg and  $m_2 = 5$  kg, are connected by a string that passes over a pulley as shown below. Mass # 1 is on a frictional surface. The system is released from rest. After 1.2 s, mass # 2 drops 1.0 m. Calculate the coefficient of kinetic friction between the surface and mass # 1.

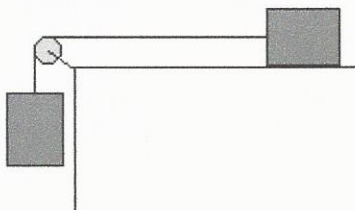

- 3) A large block of mass 25 kg is being accelerated along a frictionless surface by a horizontal force  $F$ . A smaller block of mass 4 kg is in contact with the front surface of the large block and will slide downward unless  $F$  is sufficiently large. The coefficient of static friction between the blocks is 0.71. Calculate the smallest magnitude that  $F$  can have in order to keep the block from sliding downward.

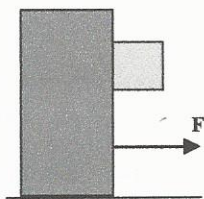

- 4) Skid of mass 45 kg is in orbit around the planet Hctim in the solar system Sraggeb. Skid is traveling at  $4.05 \times 10^4$  m/s. Hctim has a mass of  $1.9 \times 10^{27}$  kg and a radius of  $7.14 \times 10^7$  m. Calculate Skid's altitude above the surface of the planet.

- 5) An air puck of mass 0.25 kg is traveling in a circle of radius 1 m. The puck is attached to a cable that passes through a hole in a frictionless table. The other end of the cable is attached to a hanging weight of 1 kg. The air puck is moving in a circular path on the table so that the hanging weight will remain motionless. See diagram below. (a) Find the tension in the cable, (b) Name the force that is causing the air puck to move in a circle. (c) What is the velocity of the puck?

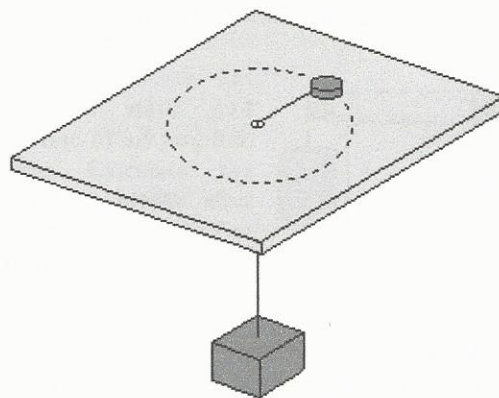

- 6) At Magic Mountain there is a ride in which people stand up against the inside wall of a large cylinder of radius 3 m. The cylinder is then spun with a velocity of 15 m/s at which point the floor drops away leaving the riders suspended against the wall. What is the minimum coefficient of static friction between the rider's clothing and the wall in order to keep the rider from sliding down?

- 7) A mass is hung from a ceiling by a cable that is 2 m in length. The mass is swung around so that it travels in a horizontal circle. While swinging the cable makes an angle of  $30^\circ$  with the vertical. Find the velocity of the mass in order to maintain the angle.

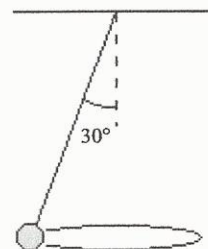

- 8) A horizontal spring with a mass of 8 kg is pulled out to a distance of 15 cm with an external force of 200 N. If the mass is released (i.e. no more external force) from this point, what will be its acceleration when it is 10 cm from equilibrium? [Do this one for Problem Set # 7] [IOW, skip it for this week.]

- 1) a) 0.445    b)  $4.38 \text{ m/s}^2$     5) a) 9.8 N    c) 6.26 m/s  
2) 0.288    6) 0.131  
3) 400 N    7) 2.38 m/s  
4)  $5.9 \times 10^6$  m    8)  $16.7 \text{ m/s}^2$

# Physics 225

Fall 2014

## Problem Set # 7

- 1) A box of mass 30 kg is being dragged from rest up a frictional ramp by a rope with tension 500 N. See diagram. The ramp has coefficients of static and kinetic friction of 0.5 and 0.3, respectively. (a) Calculate the net work done on the object if it moves 5 m up the ramp. (b) At the end of 5 m, what is the box's velocity? (Do not use motion equations.)

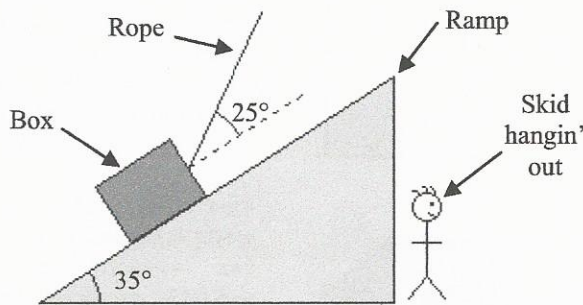

- 8) An 80 N box is pushed up a 30° ramp by a 100 N force that is applied parallel to the ramp surface. The ramp has coefficients of static and kinetic friction of 0.8 and 0.22, respectively. The box is moved 20 m up the ramp. Calculate the change in kinetic energy of the box while it is moved up the ramp.

- 9) Two masses,  $m_1 = 10$  kg and  $m_2 = 20$  kg, are connected by a string that passes over a pulley as shown below. The system is released from rest. (a) If the surface of the table is frictionless, calculate the velocity of the blocks after they have moved 2 m.

- (b) Now, the surface has coefficients of static and kinetic friction of 0.9 and 0.6, respectively. Calculate the velocity of the blocks after they have moved 2 m. (You must use energy methods for this problem.)

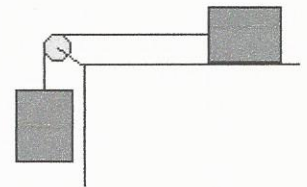

- 2) Do problem 1a) over using unit vector notation. Make your x-axis and y-axis horizontal and vertical, respectively.
- 3) An object moves from a point  $\{3, -2, 1\}$  to another point  $\{-4, 1, 2\}$  while a force  $F = (3x + 1)\mathbf{i} - 2\mathbf{j} + 6z^2\mathbf{k}$  acts on it. Calculate the work done by the force.

- 4) Skid is dragged kicking and screaming to Mike's Physics class. A force of 100 N is applied to Skid over a distance 50 m. If it takes 5 minutes to do this, what is the power required?

**NOTE: You must use energy methods for the next six problems in order to get full credit.**

- 5) A projectile is launched at an angle of 60° above the horizontal with a velocity of 40 m/s. Calculate the maximum height of the projectile while it is flying through the air.

- 6) A block of mass 0.25 kg is placed on a vertical spring of constant  $5 \times 10^3$  N/m. The block is pushed down in order to compress the spring 0.1 m. The block is released from this position. It is forced upwards and eventually leaves the spring and continues traveling up. Calculate the maximum height above the point of release that the block will achieve.

- 7) A block is at the base of a ramp of angle 35°. The ramp is 5 m long and has coefficients of static and kinetic friction of 0.6 and 0.2, respectively. If the block is initially given a velocity of 12 m/s up the ramp, what will be its velocity right before it hits the ground?

- 10) You and your posse are riding a roller coaster with no friction. The first tall peak is 140 m high which is followed by a valley that is 10 m high with a radius of curvature of 12 m. The next peak is 60 m high with a radius of curvature 25 m. (a) If the car just barely starts from rest at the first tall peak, what is the velocity of the car at the bottom of the valley? (b) How hard is the car seat pushing up on you? (You have a mass of 35 kg.) (You don't have to use energy methods for this one.) (c) What would be the required height of the first tall peak in order for the car, at the 60 m high peak, just barely not to fly off the track?

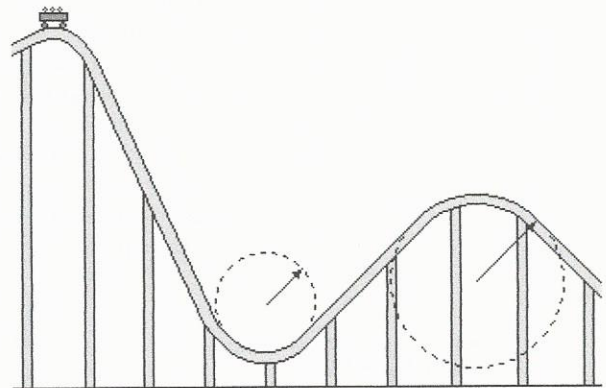

- 1) a) 1378 J b) 9.59 m/s 7) 11.3 m/s  
3) 11.5 J 8) 895 J  
4) 16.7 W 9) a) 5.11 m/s b) 4.28 m/s  
5) 61.2 m 10) a) 50.5 m/s, b) 7781 N  
6) 10.2 m c) 72.5 m