

Solar energy resource

Source: The Sun, where nuclear reaction (Fusion) releases enormous quantities of energy, radiating outward.

The energy travels into space in the form of visible light and other radiation.

Radiation: Energy that emits from a source in the form of waves or particles.

Tremendous energy: Earth receives around **170 million GW** of power from the sun, **millions times greater** than the Earth maximum power demand.

Photons: **Light energy particles**. They have no physical mass, but carry big amounts of energy and momentum.

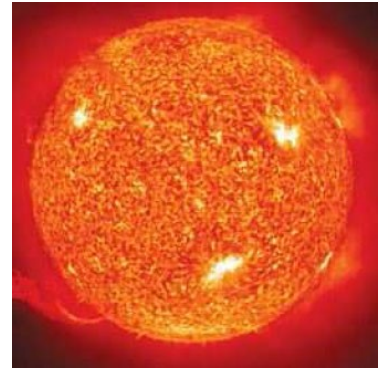

Solar radiation (1)

Extraterrestrial solar radiation: Solar radiation just outside Earth's atmosphere, also known as top-of-atmosphere (TOA) radiation.

Solar irradiance (insolation, denoted by H): A measure of solar radiation as power per unit area (W/m^2) or as energy per unit area (Wh/m^2).

- At the surface of Earth, the magnitude of solar irradiance changes during the day.
- In space, solar irradiance remains relatively constant for a given distance from the sun because there is no atmosphere to scatter and absorb the energy.

Solar constant: The average extraterrestrial solar irradiance at a distance of 1 AU (93 million miles) from the sun, $\approx 1366 \text{ W}/\text{m}^2$.

Solar radiation (2)

Terrestrial solar radiation: Solar radiation reaching the surface of Earth.

- The amount of solar power reaching Earth surface varies significantly.
- Earth atmosphere and climate conditions reduce solar radiation. Hence, its value is **always less than the solar constant**.

Peak sun: Peak sun is an estimate of terrestrial solar irradiance around solar noon at sea level.

Accepted value: **1000 W/m² (\approx 2/3 solar constant)**.

Solar radiation (3)

Peak sun hours: An equivalent measure of total solar irradiation (e.g. in a day).

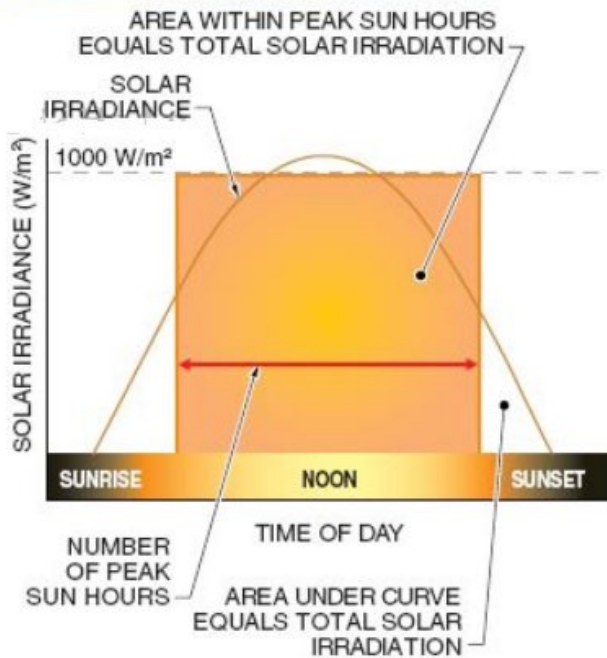

Example:

- Consider a day with an average irradiance $H=600 \text{ W/m}^2$ for 8h.
- Total irradiation: $600 \times 8 = 4,800 \text{ Wh/m}^2$.
- Total radiation is equivalent to 4.8 peak sun hours i.e.
 $4,800 / 1000 = 4.8$ peak sun hours.

Atmospheric effects on radiation (1)

- Solar radiation is **absorbed, scattered, and reflected** by components of the atmosphere, including ozone, carbon dioxide, water vapor, other gases and particles.
- **Cloud cover and local conditions** such as dust storms, air pollution, and volcanic eruptions can also greatly reduce the amount of radiation reaching some areas.
- **Major types of radiation: Direct radiation** and **diffuse radiation**.
- **Total global radiation** is the solar radiation reaching Earth surface and is the **sum of direct and diffuse radiation**.

Atmospheric effects on radiation (2)

1) Direct radiation: Solar radiation directly from the sun that reaches Earth surface without scattering. Extraterrestrial radiation is composed entirely of direct radiation.

2) Diffuse radiation: Solar radiation that is scattered by the atmosphere and clouds.

- Scattering causes radiation to be dispersed in many directions.
- A point on Earth may receive diffuse radiation from many directions at once, in addition to direct radiation.

Diffuse radiation proportion: Varies from about **10%-20%** of total global radiation for clear skies, **up to 100%** for overcast skies.

→ Typical flat-plate **PV arrays utilize both the direct and diffuse** components of the total global radiation.

Atmospheric effects on radiation (3)

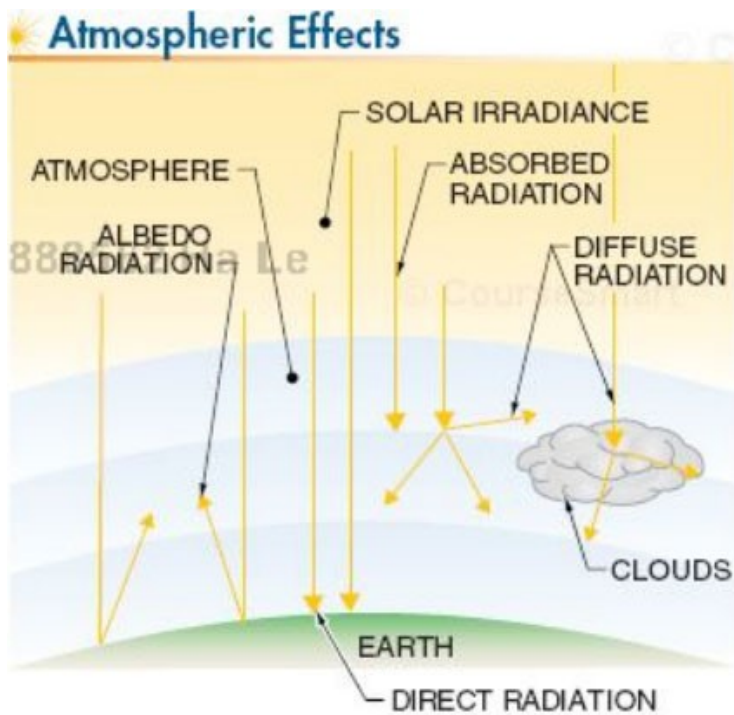
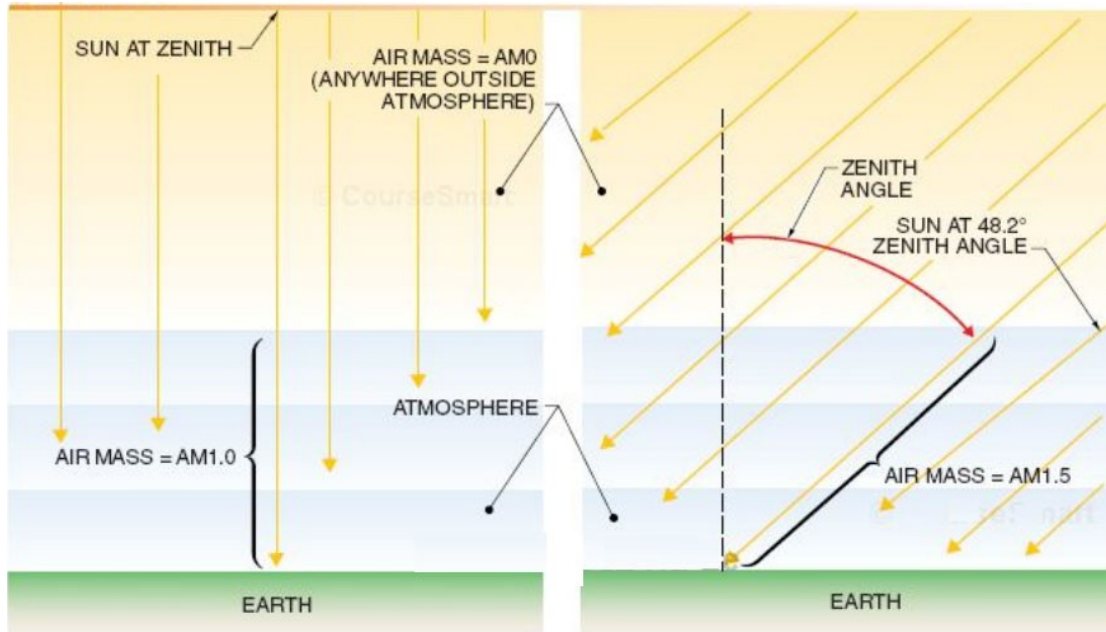

Figure 2-8. Solar radiation in Earth's atmosphere includes direct, diffuse, and albedo radiation.

Albedo radiation: Another source of **diffuse radiation**.

- Albedo radiation is **solar radiation that is reflected from the Earth surface to the atmosphere, then scattered into space**.
- This type of radiation is **generally not usable by PV devices**, except by highly tilted collectors or for the fraction that scatters in the atmosphere and adds to the diffuse radiation.

Atmospheric effects on radiation (4)



Air mass (AM): Representation of the relative thickness of atmosphere that solar radiation must pass through to reach a point on Earth's surface.

Air mass = 1.0 when the **sun is directly overhead at sea level**, designated as AM1.0. **Greater values** of AM indicate greater **attenuating effects** of the atmosphere.

Atmospheric effects on radiation (5)

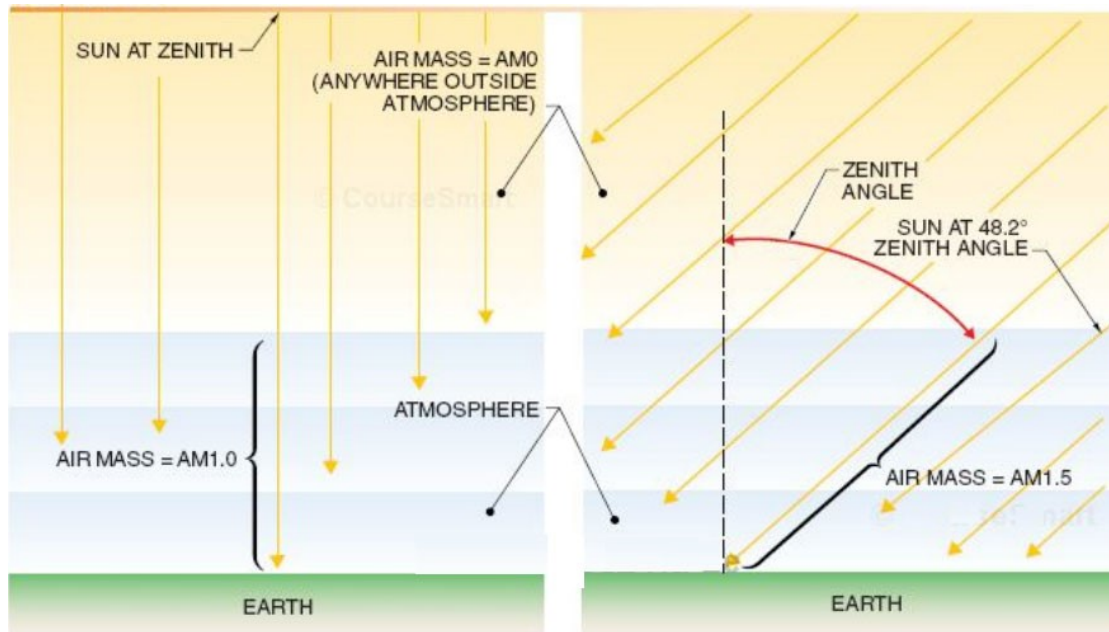

Zenith: The point in the sky directly overhead a particular location.

Zenith angle: The angle between the sun and the zenith.

→ As the **zenith angle increases**, the sun rays must pass through a **greater amount of atmosphere** to reach Earth surface.

Zenith angle calculation

The **sun zenith angle for air mass calculations** can be determined by using a vertical ruler of known height and measuring the length of shadow cast.

The ruler, shadow, and rays of the sun form a triangle.

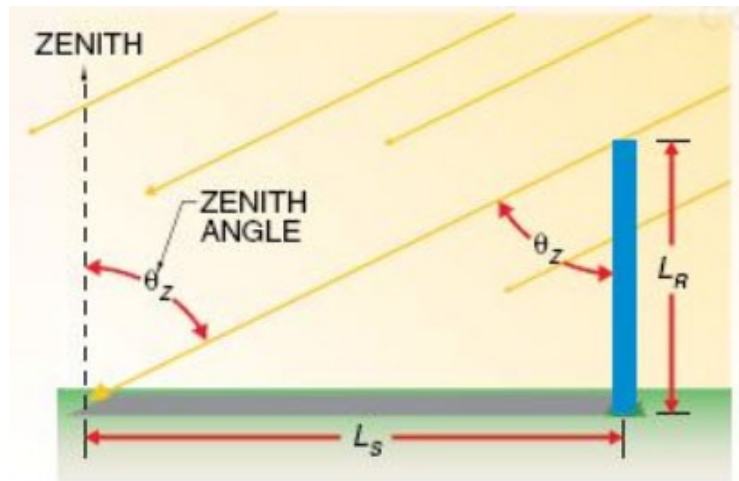

$$\theta_Z = \arctan (L_S / L_R)$$

θ_Z = zenith angle (degrees)

L_S = length of the shadow (m, cm, or in)

L_R = length of ruler (m, cm, or in)

Air mass calculation

Air mass is calculated as

$$AM = \frac{p_{local}}{1013 \cos \theta_z}$$

AM = air mass

p_{local} = local atmospheric pressure (in mbar)

1013 = atmospheric pressure at sea level (in mbar)

θ_z = zenith angle (in deg)

Example: Determine the air mass for Denver, CO, if the sun is at a 53° zenith angle and the local atmospheric pressure is 836 mbar.

$$AM = \frac{836}{1013 \times \cos 53^\circ} = 1.37$$

Solar radiation maps (1)

- **Color-coded maps** showing how insolation varies for different regions of the country and for different times of the year.
- **Insolation** (denoted as **H**) is typically expressed as **kWh/m²/day** or **equivalent peak sun hours**.
- Insolation is usually used to **rate the solar energy potential** of a location.

Solar radiation maps (2)

- **In U.S.**, these maps show national **PV resource** and **concentrating solar power (CSP) resource** potential.
- The solar maps provide **monthly average daily total solar resource (insolation)** information on grid cells (10x10km or 40x40km in size).
- They are **spatial interpolations of solar radiation values** derived from the 1961-1990 National Solar Radiation Data Base (NSRDB).
- The **maps are available from NREL** (National Renewable Energy Laboratory).

Solar radiation maps (3)

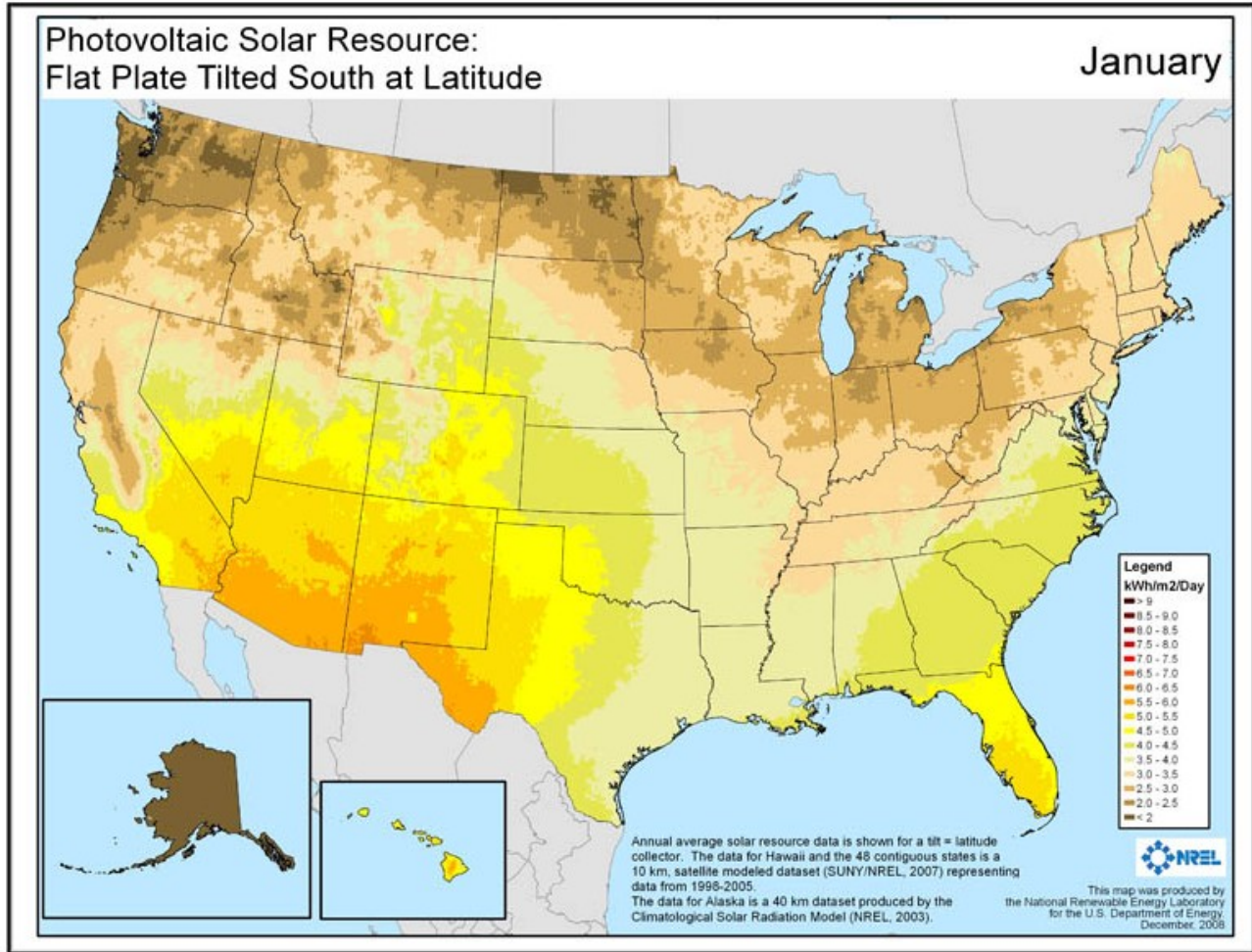

Solar radiation maps (4)

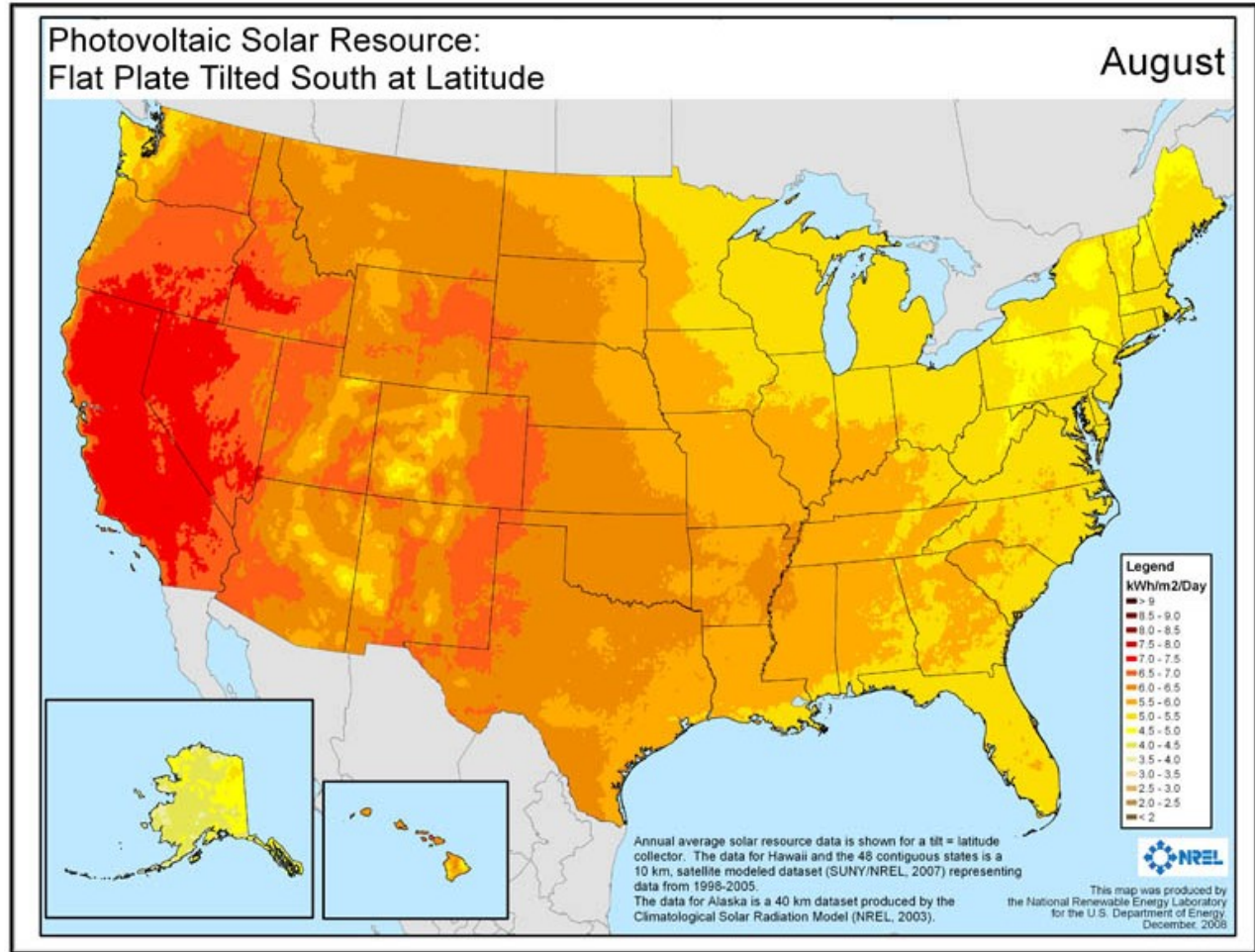

Solar radiation measurement



Pyranometers: A device that measures the **total global solar irradiance** in a hemispherical field of view.



Diffuse radiation: Can be measured by shading a pyranometer using an arc-shape metal strip to shield direct radiation.



Direct radiation: Can be calculated by subtracting the diffuse measurement from the global measurement.

Pyrheliometers: Measures **ONLY direct radiation**. It must be pointed directly at the sun and installed on sun-tracking devices.

Solar declination

- **Solar declination** is the angle between the equatorial plane and sun rays.

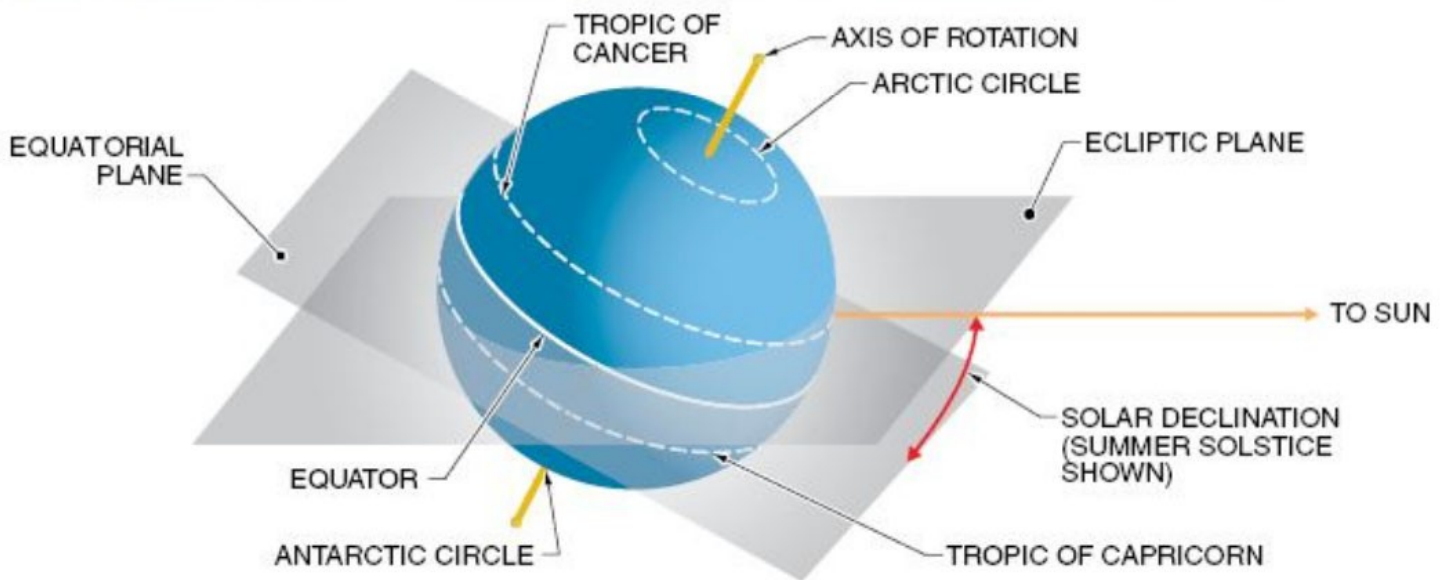

Solstice and Equinox (1)

- A **solstice** is **Earth orbital position** where **solar declination** is at its **minimum** (-23.5° , winter) or **maximum** ($+23.5^{\circ}$, summer).
- An **equinox** is **Earth orbital position** when **solar declination is zero**.

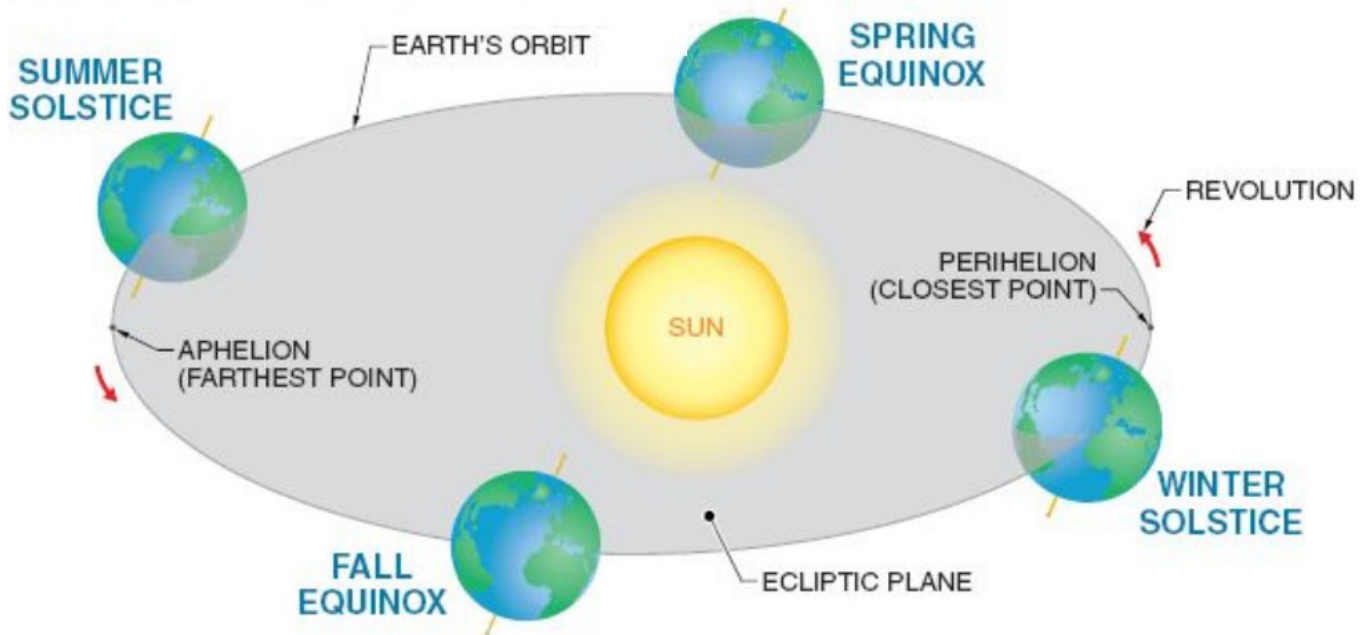

Solstice and Equinox (2)

- A more realistic look at **solstice** and **equinox**

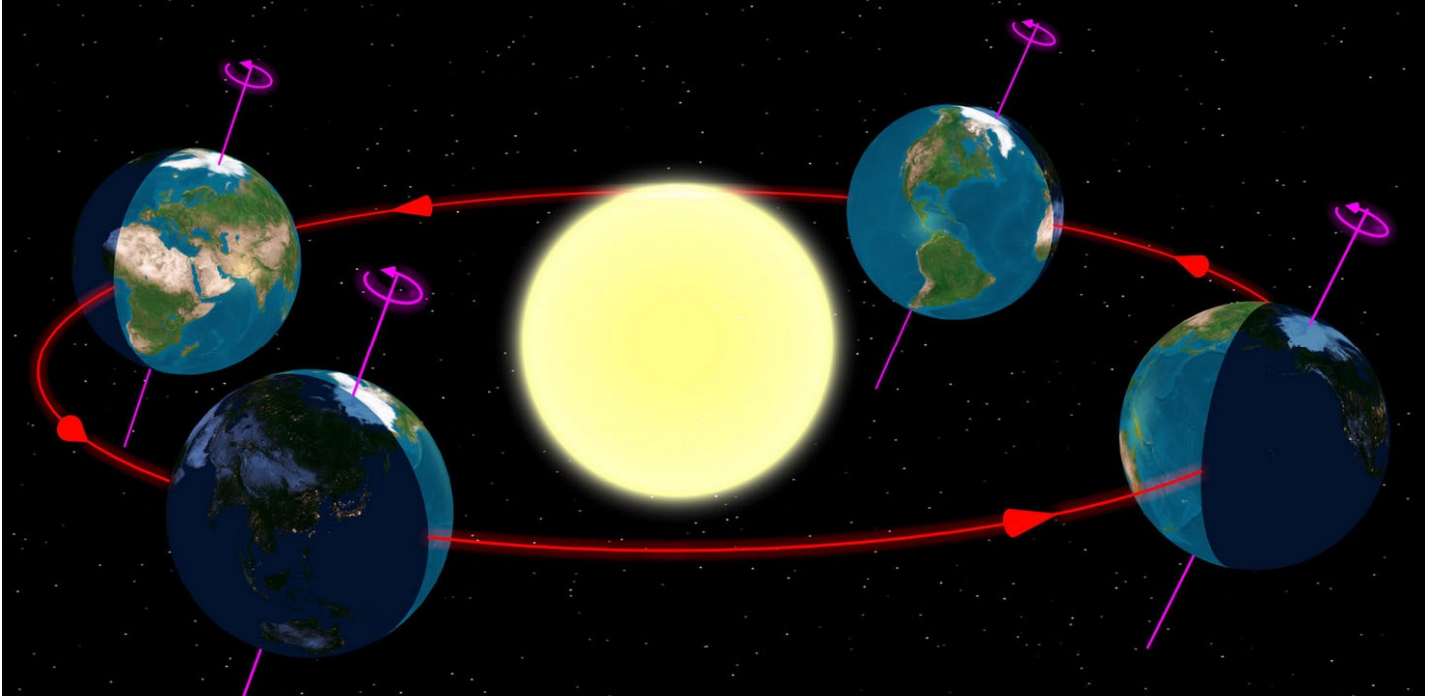

Sun path chart (1)

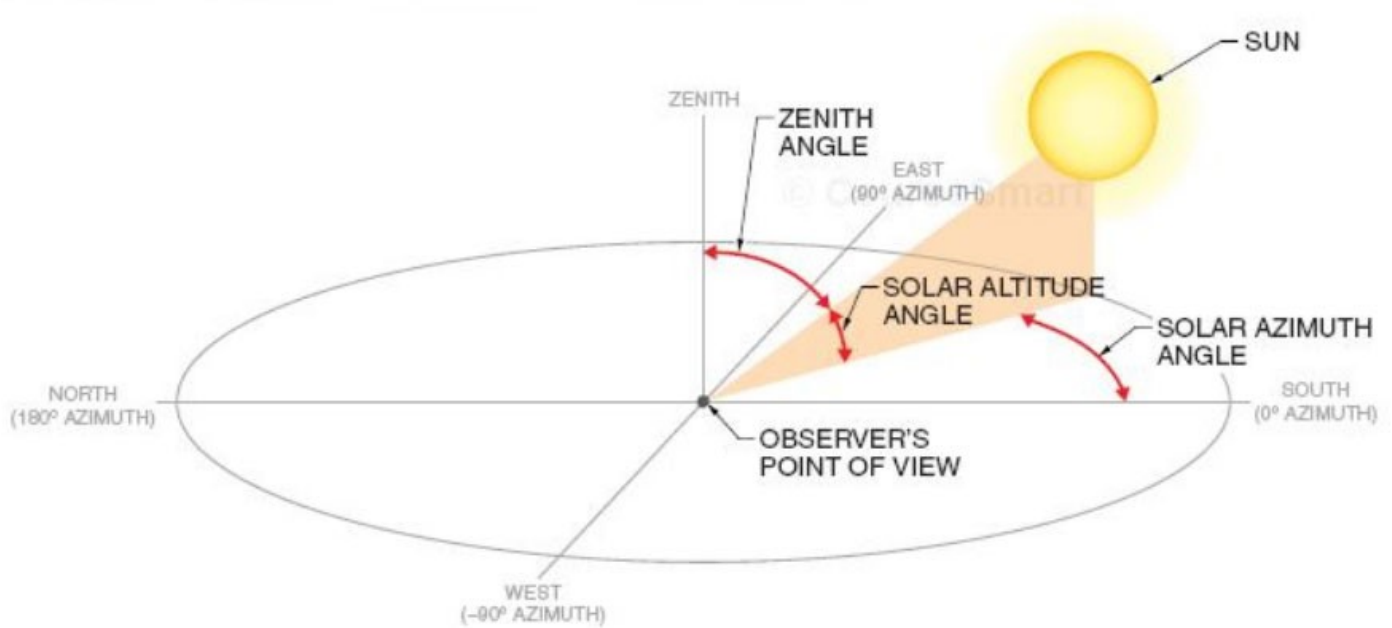

Sun position:

Two angles are used to define the sun position, relative to an observer on Earth: **Solar altitude angle & Solar azimuth angle.**

Sun path chart (2)

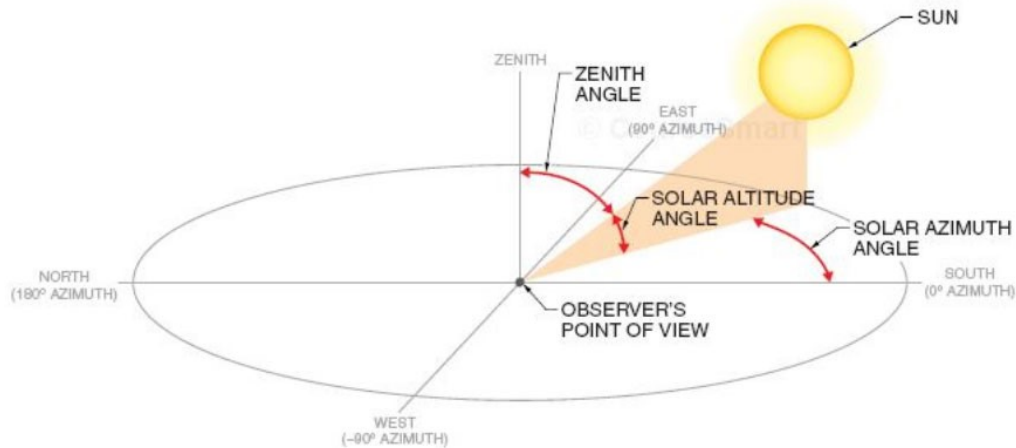

Solar altitude angle: Vertical angle between the **sun and the horizon**. During daytime, this angle varies between 0° and 90° and complements the zenith angle (sum of the two equals 90°).

Solar azimuth angle: Horizontal angle between a **reference direction** (due south in the Northern Hemisphere) **and the sun**. This angle varies between -180° and $+180^{\circ}$.

Sun position to the east of reference direction is **positive** and to the west is **negative** azimuth angle.

Sun path chart (3)

Sun path chart: Plot of **solar azimuth angle** versus **solar altitude** to indicate the range of sun positions for a particular location.

The chart can be a table or a figure (shown below).

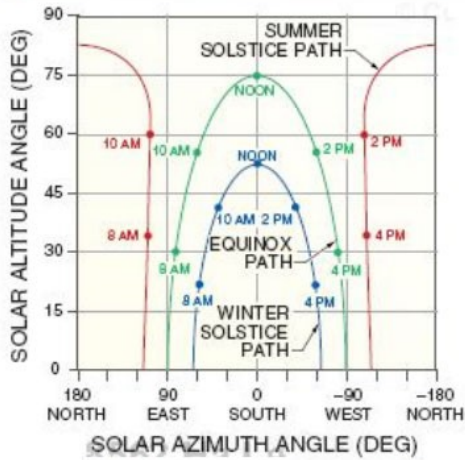

SUN PATHS FOR 15°N LATITUDE

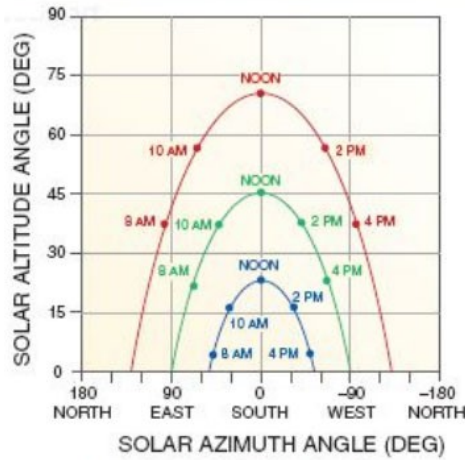

SUN PATHS FOR 45°N LATITUDE

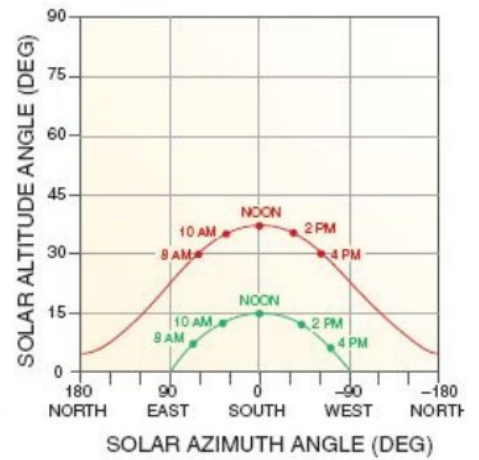

SUN PATHS FOR 75°N LATITUDE

➔ How to interpret the Sun path chart?

Sun path chart (4)

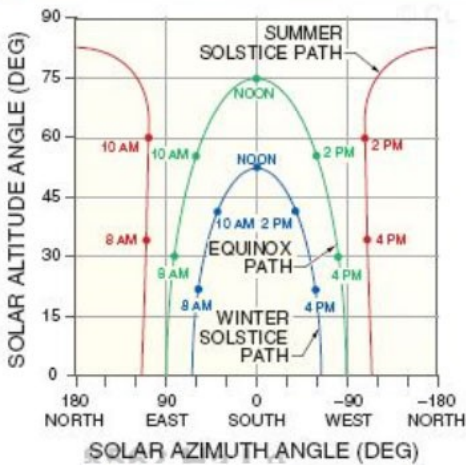

SUN PATHS FOR 15°N LATITUDE

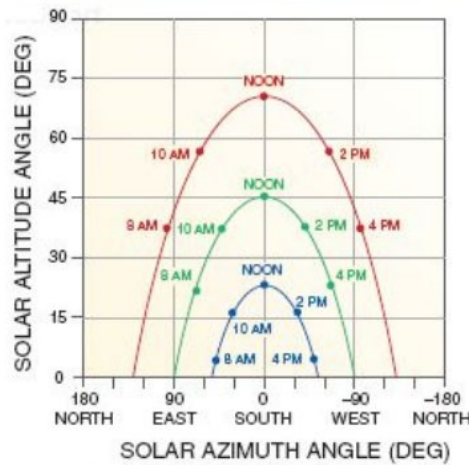

SUN PATHS FOR 45°N LATITUDE

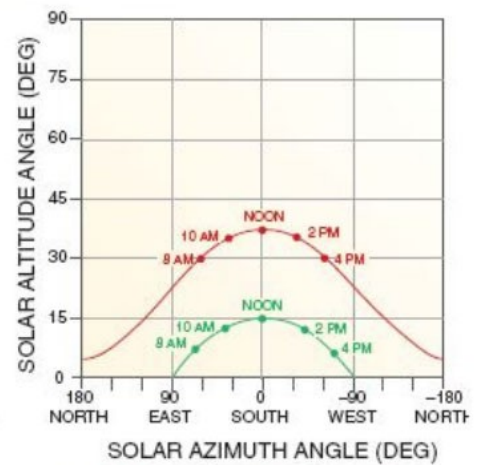

SUN PATHS FOR 75°N LATITUDE

- **Sun path for 45° N latitude (middle latitude):** 3 paths look similar. But the sun is lower in the sky for latitudes farther north.
- **Sun path for 15° N latitude (< 23.5°):** The summer solstice appears different, since the sun is never in the southern half of the sky (azimuth angles between -90° and +90°).
- **Sun path for 75° N latitude (above the Arctic Circle):** The sun never appears above the horizon at the winter solstice. The sun never sets at the summer solstice.

Solar window

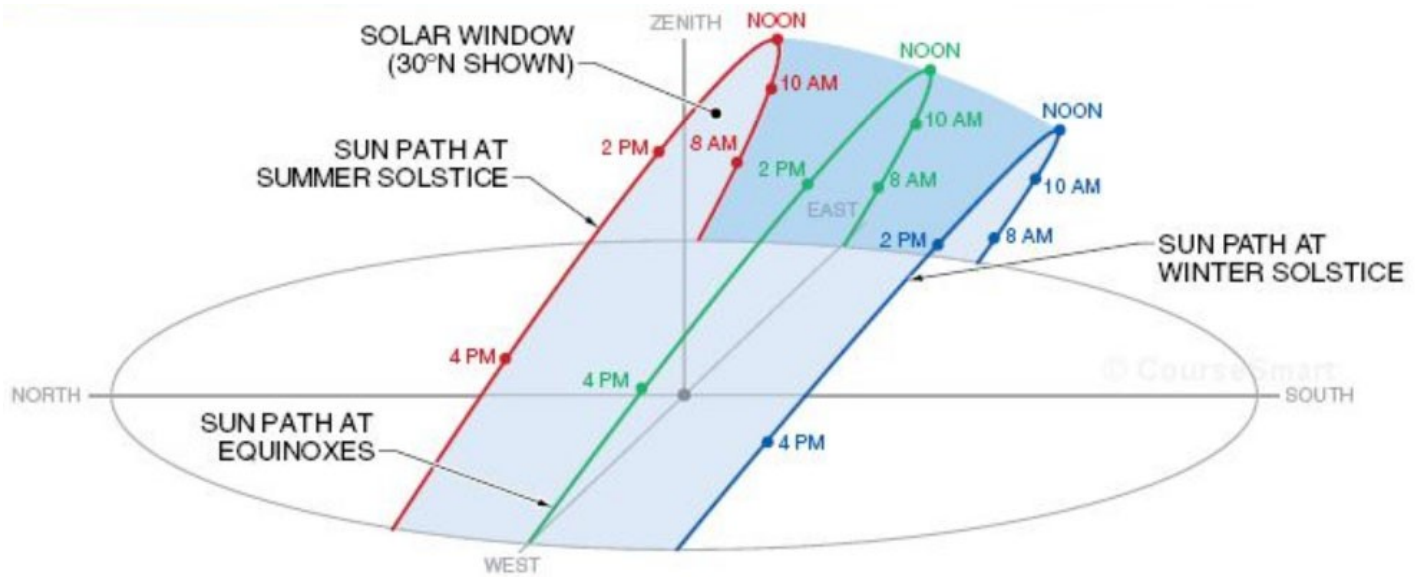

Solar window: The area of sky between **sun paths at summer solstice and winter solstice** for a particular location. The area contains **all possible locations** of the sun throughout the year for the location.

Use of sun path chart and solar window

→ **Sun path:** Useful for operating PV arrays for optimal energy performance (e.g. sun tracking).

→ **Solar window:** Critical for

- properly locating and orienting PV arrays to achieve optimal energy performance.
- preventing shading from trees and other obstructions.

PV array orientation (1)

- The orientation of PV array surface impacts the amount of solar radiation that can be utilized by a PV system. The orientation is defined by two angles, **array tilt angle** and **array azimuth angle**.
- **Array tilt angle:** Vertical angle between horizontal and the array surface.
- **Array azimuth angle:** Horizontal angle between a reference direction (either due north or due south) and the direction an array surface.

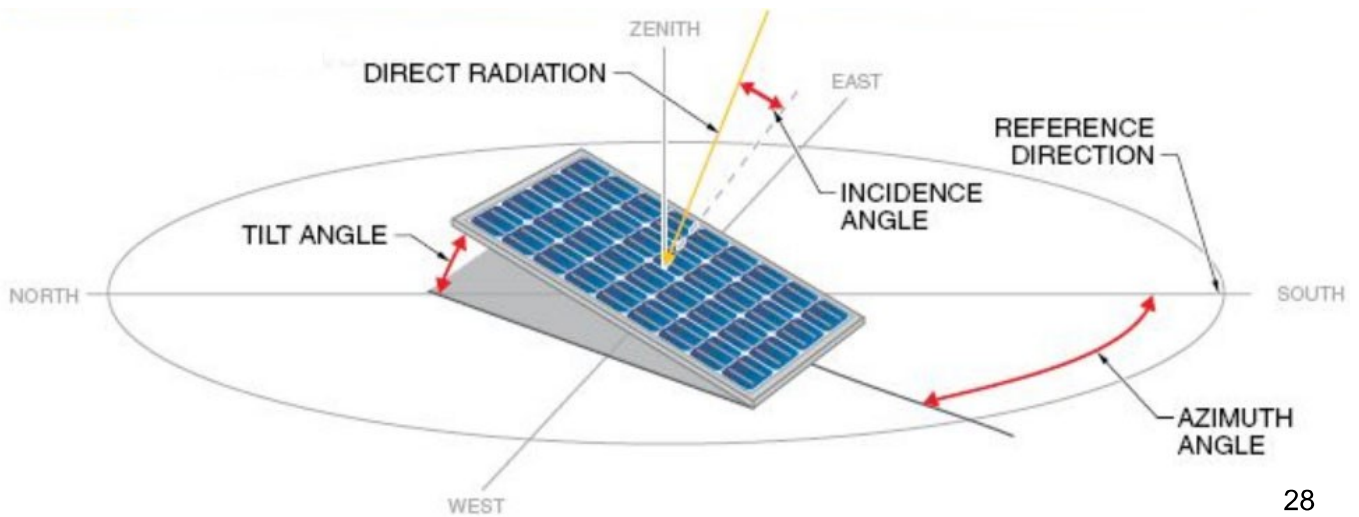

PV array orientation (2)

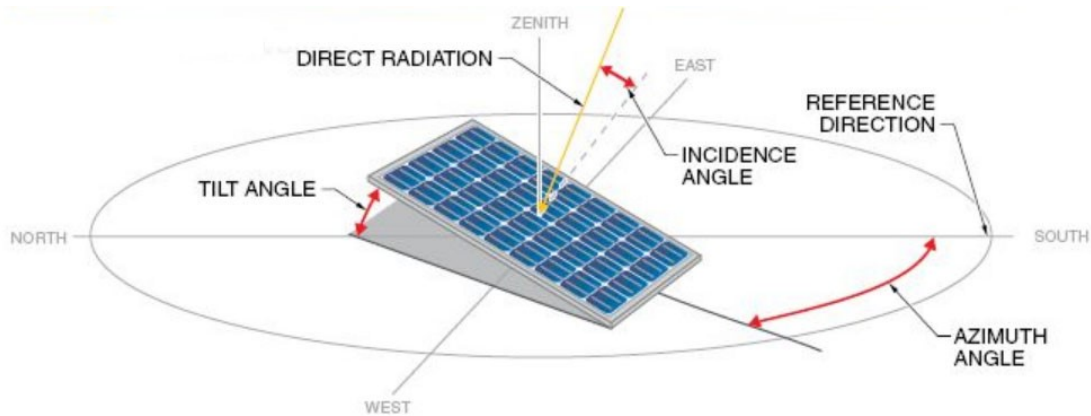

- The sun position and array orientation determine the **incidence angle of direct solar radiation**.
- **Incidence angle:** Angle between the sun rays and a line perpendicular to the array surface.
- **Maximum solar radiation** is received when the **incidence angle is 0°** .
- For a fixed surface, the incidence angle changes as the sun moves through the solar window.

Optimal array tilt angle (1)

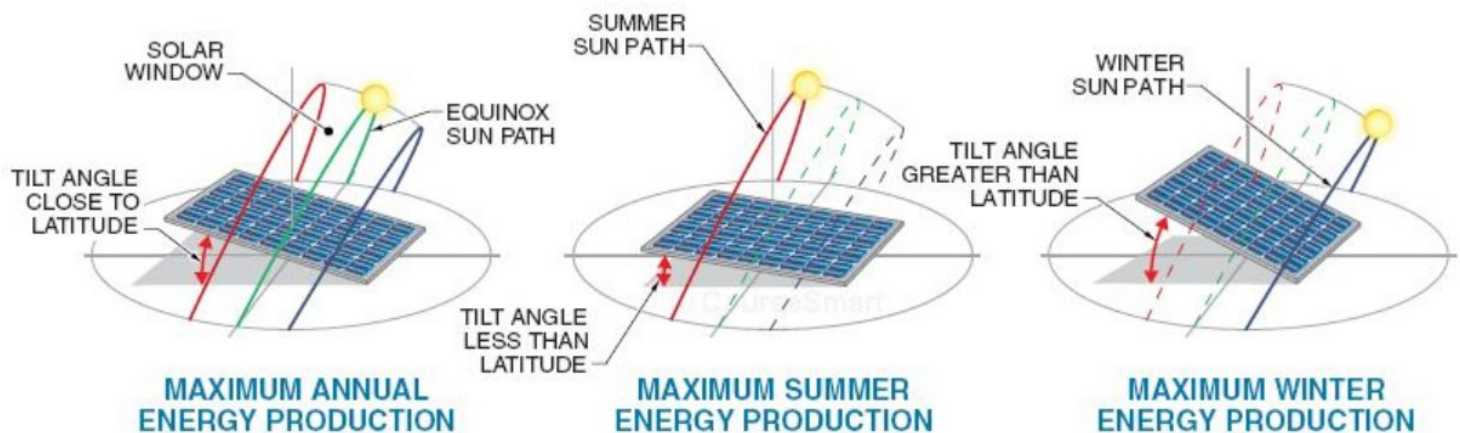

- **Maximum annual solar energy gain on a fixed surface:** Achieved by orienting the surface at a **tilt angle close to the value of the local latitude**. → Seasonal sun path changes and local climate variations may affect the optimal tilt angle.
- **Maximizing summer energy:** **Smaller tilt angles** needed to take advantage of the sun high arc through the summer sky.
- **Maximizing winter energy:** **Greater tilt angles** needed to receive more energy when the sun is lower in the winter sky.

Optimal array tilt angle (2)

Seasonal declinations: For skewing energy performance toward a specific time of year, the **tilt angle is adjusted from the latitude angle by 15°**.

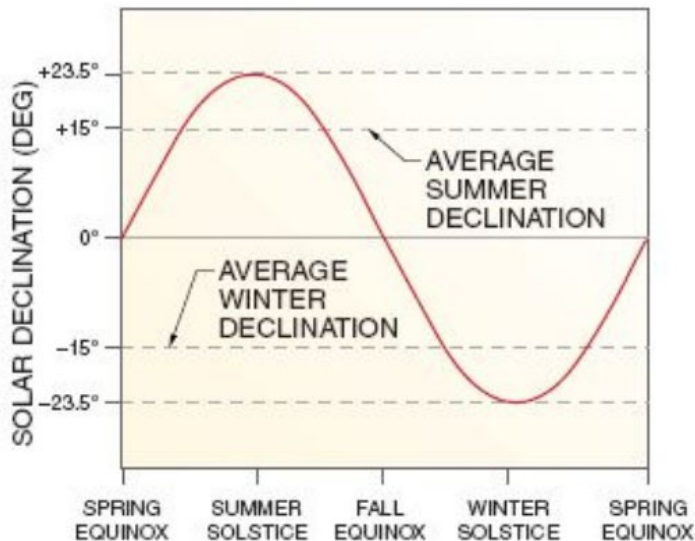

- **Summer:** Tilt angle = **latitude - 15°**, so that the array is perpendicular to the average solar path in the sky during the summer.
- **Winter:** Tilt angle = **latitude + 15°**, so that the array is perpendicular to the average solar path in the sky during the winter.
- Solar radiation resource datasheets for specific sites often includes data for surfaces at **latitude**, **latitude - 15°**, and **latitude + 15°** tilt angles.

Practice: Optimal array tilt angle

The figure below shows PV array installation for a house in Los Angeles, CA.

Is it an efficient installation in terms of solar energy capture?



Array azimuth angle

→ **Optimal azimuth angle** for total energy gain is **due south** (or **due north** in the Southern Hemisphere) for fixed PV arrays.

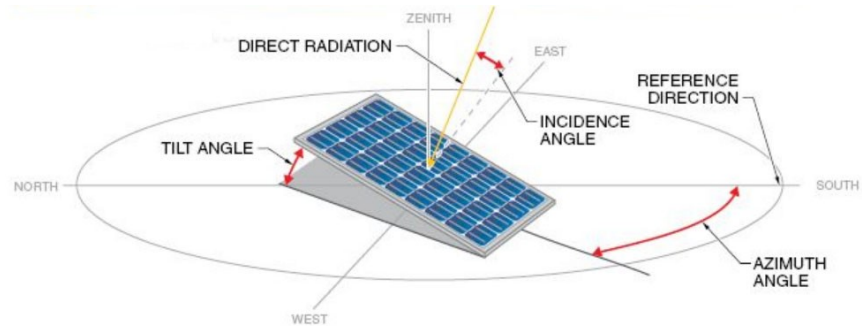

- The azimuth angle of array installations on existing structures may be constrained by factors such as the orientation or roof pitch of the building.
- **Less solar energy is received** when a **fixed array is oriented to an azimuth angle other than due south.**
- **This reduction increases with larger tilt angles.**
- Tilt surfaces with azimuth orientations of $\pm 45^\circ$ from due south will receive at least 95% of the annual solar energy received on true south-facing surfaces (Most middle and southern U.S. latitudes).

Sun tracking

- **Sun tracking** is continuously **changing the array tilt angle**, the **array azimuth angle**, or **both**, so the array follows the position of the sun.
- Hence, the incidence angle is always close or equal to 0° , **increasing annual solar gain by as much as 40%**.

Type of sun tracking:

Single-axis tracking: Rotating one axis to **approximately follow the sun position**. The mount may rotate the vertical axis, which changes the azimuth angle, or the north-south axis, which allows the array to follow the sun from east to west.

Dual-axis tracking: Rotating two axes independently to **exactly follow the sun position**. This further increases the amount of solar energy received, compared to single-axis tracking.

Solar radiation data sets (1)

- **Solar radiation data** indicates how much solar energy strikes a surface at a particular location on Earth during a particular period of time.
- **PV systems produce electrical energy in direct proportion to the amount of solar energy received** on the surface of the array.
- **NREL Solar Radiation Data Manual for Flat-plate and Concentrating Collectors** accounts for **variations in site and weather conditions** by including monthly average, minimum, and maximum values from data collected over the 30-year period (1961 -1990).
- The database includes data for **239 sites** throughout the U.S.

Solar radiation data sets (2)

NREL Solar Radiation Data Set Excerpt

Location Knoxville, TN (35.82°N, 83.98°W) Elevation 299 m Pressure 983 mbar													
SOLAR RADIATION FOR FLAT-PLATE COLLECTORS FACING SOUTH AT A FIXED TILT*													
Tilt Angle	Jan	Feb	Mar	Apr	May	Jun	Jul	Aug	Sept	Oct	Nov	Dec	Annual
0	2.3	3.0	4.0	5.2	5.8	6.2	5.9	5.5	4.5	3.7	2.5	2.0	4.2
Latitude -15	3.0	3.7	4.6	5.5	5.8	6.1	5.8	5.7	5.0	4.6	3.3	2.8	4.7
Latitude	3.4	4.0	4.7	5.4	5.5	5.6	5.4	5.5	5.1	4.9	3.7	3.1	4.7
Latitude +15	3.6	4.1	4.6	5.0	4.9	4.9	4.8	5.0	4.8	4.9	3.8	3.3	4.5
90	3.2	3.3	3.2	2.9	2.4	2.2	2.3	2.7	3.2	3.8	3.3	3.0	3.0
SOLAR RADIATION FOR FLAT-PLATE COLLECTORS WITH 1-AXIS (NORTH-SOUTH) TRACKING*													
Tilt Angle	Jan	Feb	Mar	Apr	May	Jun	Jul	Aug	Sept	Oct	Nov	Dec	Annual
0	3.1	4.0	5.2	6.7	7.3	7.8	7.3	6.9	5.8	5.0	3.4	2.7	5.5
Latitude -15	3.6	4.6	5.7	6.9	7.4	7.7	7.3	7.1	6.2	5.7	4.0	3.3	5.8
Latitude	3.9	4.8	5.8	6.9	7.1	7.4	7.1	7.0	6.3	5.9	4.3	3.6	5.8
Latitude +15	4.1	4.9	5.7	6.6	6.7	6.9	6.6	6.7	6.1	6.0	4.4	3.7	5.7
SOLAR RADIATION FOR FLAT-PLATE COLLECTORS WITH 2-AXIS TRACKING*													
	Jan	Feb	Mar	Apr	May	Jun	Jul	Aug	Sept	Oct	Nov	Dec	Annual
2-Axis Tracking	4.1	4.9	5.8	7.0	7.4	7.9	7.4	7.2	6.3	6.0	4.4	3.8	6.0

Example use of data: Compare the solar radiation data for flat-plate collectors facing south at fixed tilts of 0° and latitude.

Average annual solar radiation: 4.2 at 0° and 4.7 at latitude (in kWh/m²/day)

→ Tilting the collector to an angle equal to the latitude increases the average daily peak sun hours received by $100 * (4.7 - 4.2) / 4.2 = 12\%$

PV system energy production estimation

- The National Renewable Energy Lab (NREL) provides an FREE online calculator named **PV Watts**.
- Web: <https://pvwatts.nrel.gov/index.php>
- It estimates annual energy production for any PV system based on the system location.
- NREL provides other solar tools such as financial and economic calculators.
- **Note:** For actual PV system design, other methods may need to be developed.

Photovoltaic cell, module, array

- **Photovoltaic (PV) cell**, or solar cell, produces electricity from sunlight. Individual cells produce very small amounts of power, so many must be connected together to create bigger amounts of power.
- **PV module**: A PV device consisting of a number of individual cells connected electrically, laminated, encapsulated, and packaged into a frame.
- **PV array**: A complete PV power generating unit consisting of a number of integrated modules with structural supports, trackers, or other components.

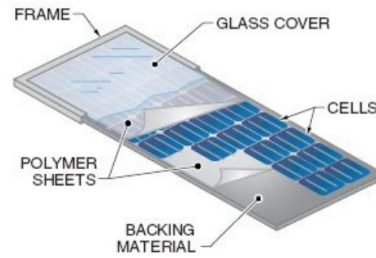
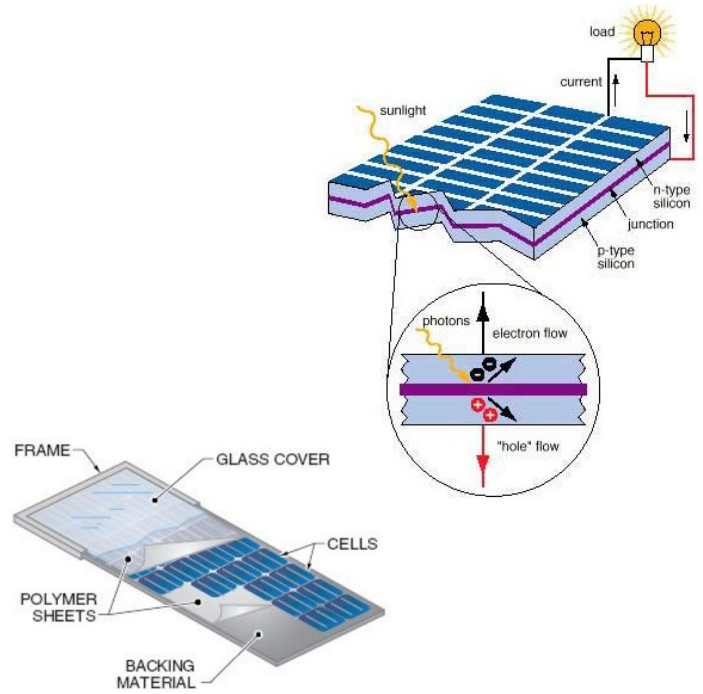

Photovoltaic cell

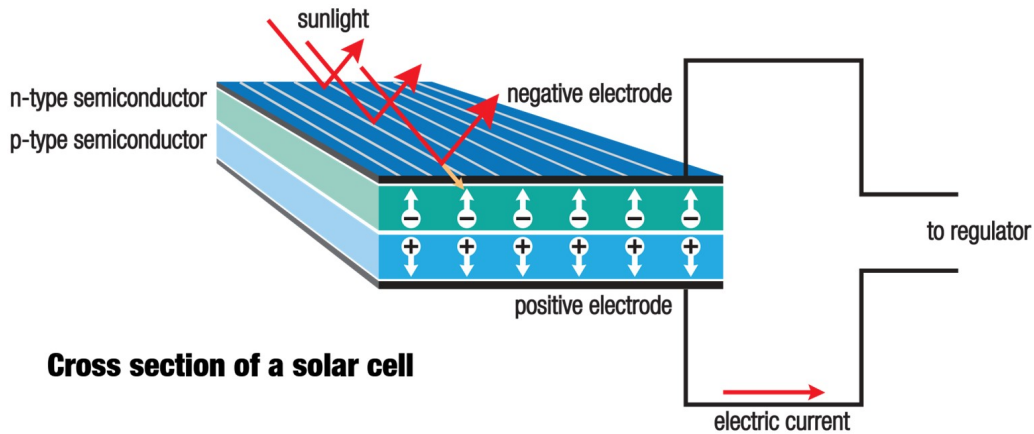

- **Two layers of a semi-conducting material** are combined to form a solar cell. **One layer typically has a depleted number of electrons while the other layer has a surplus in electrons.** When exposed to sunlight, the **layers of material absorb the photons.**
- This excites the electrons, causing **some of them to move from one layer to the other**, generating an electrical charge. This movement of electrons is called **Photovoltaic effect.**
- When a load is connected to the cell terminal, **a current flows.**

Semiconductors (1)

- PV cells are made from **semiconductor materials**.
- **Semiconductor:** A material that can exhibit properties of both an insulator and a conductor.
- Semiconductors behave like insulators at very low temperature and their conductivity increases with temperature.
- **Most PV cells use variations of silicon altered by doping** to make them suitable semiconductors.
- **Doping:** Process of adding small amounts of impurity elements to semiconductors to alter their electrical properties.

Semiconductors (2)

P-type semiconductor: A semiconductor that has **electron voids**.

N-type semiconductor: A semiconductor that has **free electrons**.

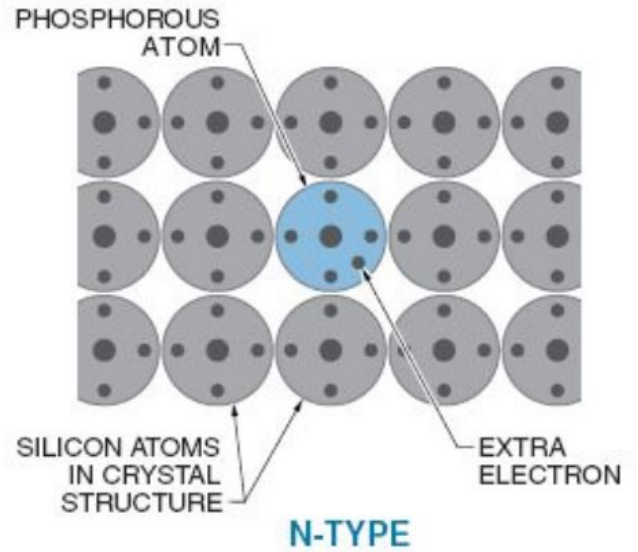
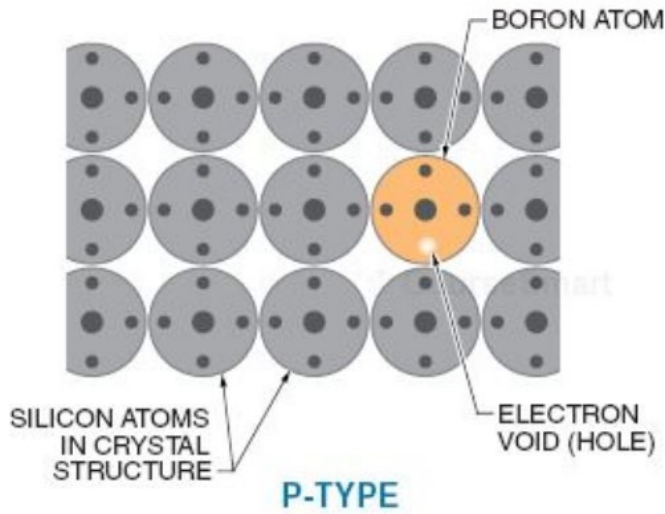

Efficiency of PV cell materials

MATERIAL	TYPICAL COMMERCIAL SAMPLE EFFICIENCY	BEST LABORATORY EFFICIENCY
Multijunction gallium arsenide (GaAs), concentrator	38 to 40	43.5
Multijunction gallium arsenide (GaAs), non-concentrator	28 to 32	34.1
Monocrystalline silicon	15 to 18	27.6
Polycrystalline silicon	11.5 to 14	20.4
Copper indium gallium selenide (CIGS)	12 to 14	20.3
Cadmium telluride (CdTe)	9 to 11	17.3
Amorphous silicon (a-Si)	8 to 9	12.5
Dye-sensitized (Grätzel)	8 to 10	11.8
Polymer (Organic)	2 to 4	10.0

* in %

Source: NREL, May 2012

PV cell fabrication

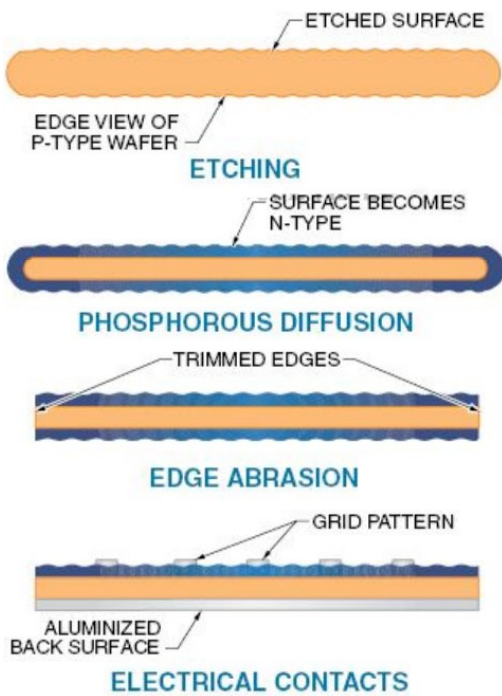

Bottom surface: **positive**

Top surface: **negative**

- 1) A **p-type wafer** is dipped in a sodium hydroxide solution to **etch the surface**. The textured surface increases surface area, allows subsequent coatings to adhere better, and minimizes reflected sunlight.
- 2) **Diffusion of phosphorous gas** creates a thin **n-type semiconductor layer** over the entire surface of a p-type wafer.
- 3) **Anti-reflective coatings** are applied to the top surface of the cell to further reduce reflected sunlight and improve cell efficiency.
- 4) **Grid patterns** are printed on the top surface of the cell to provide a point for electron collection and electrical connection to other cells.
- 5) Entire back surface of the cell is **coated with a thin layer of metal (aluminum)**, which alloys with the silicon and neutralizes the n-type semiconductor layer on the back surface.

I-V curve (1)

I-V curve: Current-voltage characteristic, the basic electrical output profile of a PV device.

- **I- V curve changes** with cell temperature and irradiance.
- A PV device can operate anywhere along its I-V curve, depending on the electrical load.

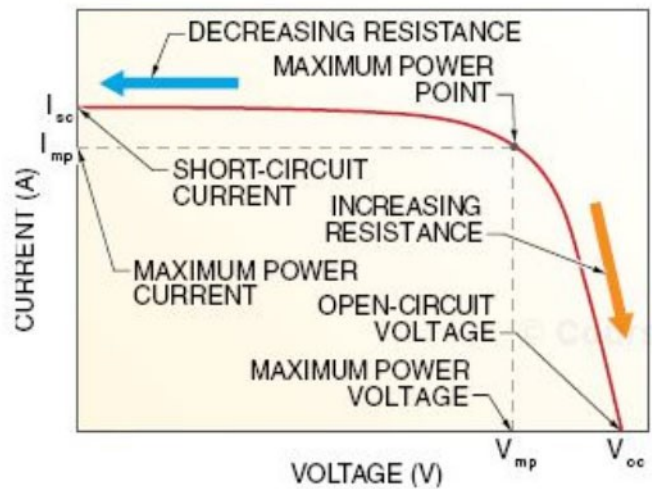

- Certain points on an I- V curve are **used to rate module performance** and are the basis for the electrical design of arrays.
- **Basic I-V curve parameters:** Open-circuit voltage (V_{OC}), short-circuit current (I_{SC}), maximum power voltage (V_{MP}), maximum power current (I_{MP}), maximum power (P_{MP}).
- I-V parameters are specified for **specific operating conditions**.

I-V curve (2)

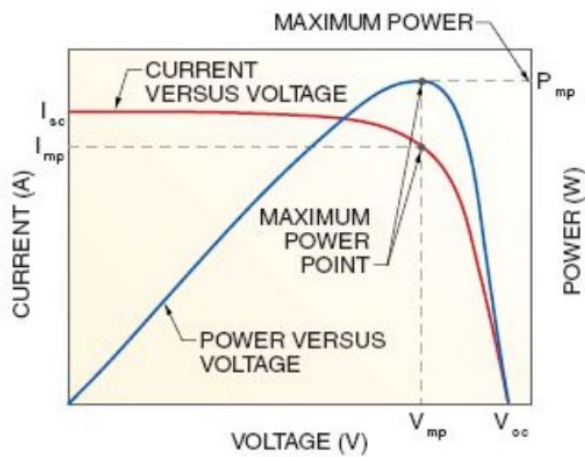
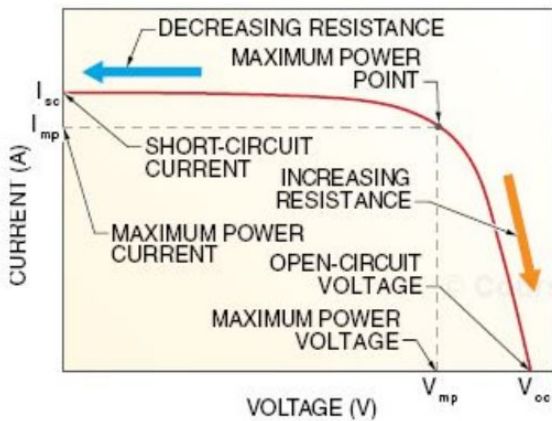

1) Open-circuit voltage (V_{oc}):

Maximum voltage on an I-V curve. Increasing cell temperature reduces V_{oc} for crystalline silicon. For individual cells, V_{oc} range is 0.5 - 1V at 25° C (77° F)

2) Short-circuit current (I_{sc}):

Maximum current on an I-V curve and is the operating point for a PV device under no-load or short-circuit condition, and no voltage output.

3) Maximum power point (P_{mp}):

Operating point on an I- V curve where the product of current and voltage is at maximum.

I-V curve (3)

4) Maximum power voltage (V_{mp}):

Operating voltage on an I-V curve where the power output is at maximum (~ 70% - 80% of V_{oc})

5) Maximum power current (I_{mp}):

Operating current on an I-V curve where the power output is at maximum (~90% of I_{sc}).

$$P_{mp} = V_{mp} * I_{mp}$$

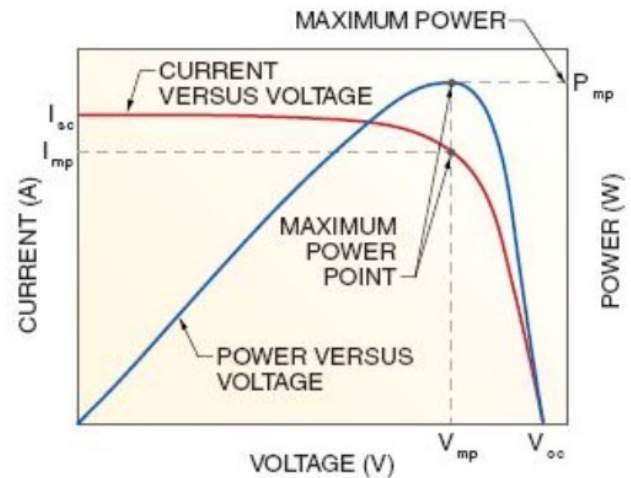

- The **maximum power point is located on the knee of the I-V curve** and is the **highest efficiency** operating point for a PV device for particular conditions of solar irradiance and cell temperature.
- The **maximum power point is used to rate the performance** of PV devices.

Fill factor (1)

Fill factor (FF): Ratio of maximum power to the product of the open-circuit voltage and short-circuit current.

- Fill factor represents the **performance quality** of a PV device and the **shape of the I- V curve**.
- Most commercial crystalline silicon PV cells have fill factors exceeding **70%**, while FF for many thin-film materials is less.

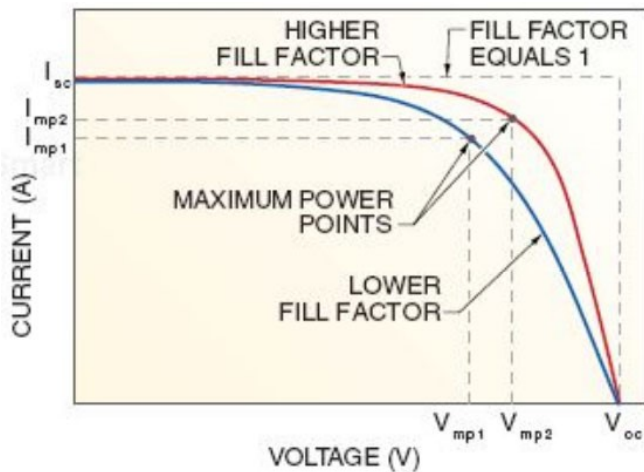

$$FF = \frac{P_{mp}}{V_{oc} \times I_{sc}}$$

FF = fill factor

P_{mp} = maximum power (W)

V_{oc} = open-circuit voltage (V)

I_{sc} = short-circuit current (A)

Fill factor (2)

Example:

What is the fill factor of a PV cell with a maximum power of 3.0 W, an open-circuit voltage of 0.6 V and a short-circuit current of 7.0 A?

Solution:

$$FF = \frac{P_{mp}}{V_{oc} \times I_{sc}}$$

$$FF = \frac{3.0}{0.6 \times 7.0} = \mathbf{0.714} \text{ or } \mathbf{71.4\%}$$

PV modular efficiency (1)

Efficiency: Ratio of power output to power input.

$$\mathbf{r = \eta = \frac{P_{mp}}{H \times A}}$$

$\mathbf{r = \eta = \text{efficiency}}$

$\mathbf{P_{mp}}$ = maximum power (in W)

\mathbf{H} = solar irradiance (in W/m²)

\mathbf{A} = area (in m²)

Example: What is the efficiency of a PV module with a surface area of 1.2m² and a maximum power output of 160W when exposed to 1000 W/m² solar irradiance?

Solution:

$$\eta = \frac{160}{1000 \times 1.2} = \mathbf{0.133 \text{ or } 13.3\%}$$

PV modular efficiency (2)

Another way to calculate PV modular efficiency is:

$$r = \text{Peak power (in kWp)} / \text{panel area (in m}^2\text{)}$$

Example : The solar panel yield of a PV module of 250 Wp with an area of 1.6 m² is

$$(250 \cdot 10^{-3}) / 1.6 = 0.156 \text{ or } 15.6\%$$

Note:

- **Peak power rating:** Maximum output under standard test conditions (STC), measured in Watt-peak (Wp) or kWp.
- **STC:** Radiation = 1000 W/m², cell temperature = 25°C, wind speed = 1 m/s, AM = 1.5.

Summary: PV module parameters

PV module performance is generally **rated under standard test conditions** (STC). **STC:** Irradiance = 1,000 W/m² (peak sun condition), AM =1.5, and module temperature at 25 °C.

Electrical characteristics:

- 1) Open circuit voltage V_{OC} (V)
- 2) Short circuit current I_{SC} (A)
- 3) Maximum power voltage V_{MP} (V)
- 4) Maximum power current I_{MP} (A)
- 5) **Peak power** (Maximum output under STC, W_p)
- 6) **Module efficiency** (%)
- 7) Nominal voltage = DC voltage for battery charging

Note: Actual voltage output changes under different load conditions.

Examples: PV module nameplate

STC	CS6P-240M	CS6P-245M
Nominal Maximum Power (Pmax)	240W	245W
Optimum Operating Voltage (Vmp)	30.2V	30.3V
Optimum Operating Current (Imp)	7.95A	8.09A
Open Circuit Voltage (Voc)	37.3V	37.4V
Short Circuit Current (Isc)	8.46A	8.61A
Module Efficiency	14.92%	15.23%
Operating Temperature	-40°C~+85°C	
Maximum System Voltage	1000V (IEC) /600V (UL)	
Maximum Series Fuse Rating	15A	
Application Classification	Class A	
Power Tolerance	0 ~ +5W	



First Solar, LLC
28101 Cedar Park Blvd.
Perrysburg, OH 43551
www.FirstSolar.com



Made in USA

Nominal Power (+/-5 %)	60 W
Current at mpp	0.97 A
Voltage at mpp	62 V
Short Circuit Current	1.15 A
Open Circuit Voltage	90 V
Maximum System Voltage	(600V UL) 1000 V
Max Source Circuit Fuse	(2A UL) 10 A
Protection Class	Class II
Cell Type	CdTe

specifications (+/- 10 %) at STC: Irrad. 1,000 W/m², AM 1.5, Cell T 25 °C

Warning - Electrical shock hazard
This solar module produces high voltages in sunlight. Read and observe all instructions before attempting installation or service. Do not disconnect under load.

Serial Number



F01260301

Model Number

FS-260

Covered by United States Patents: 5,248,349; 5,470,397; 5,536,333; 5,945,163; 6,037,241; 6,559,411; 6,719,848; and by Corresponding Foreign Patents; Others Pending.

PV energy output calculation (1)

Power losses in PV systems: Significant, varies, depends on many factors.

**Total loss:
~ 84%**

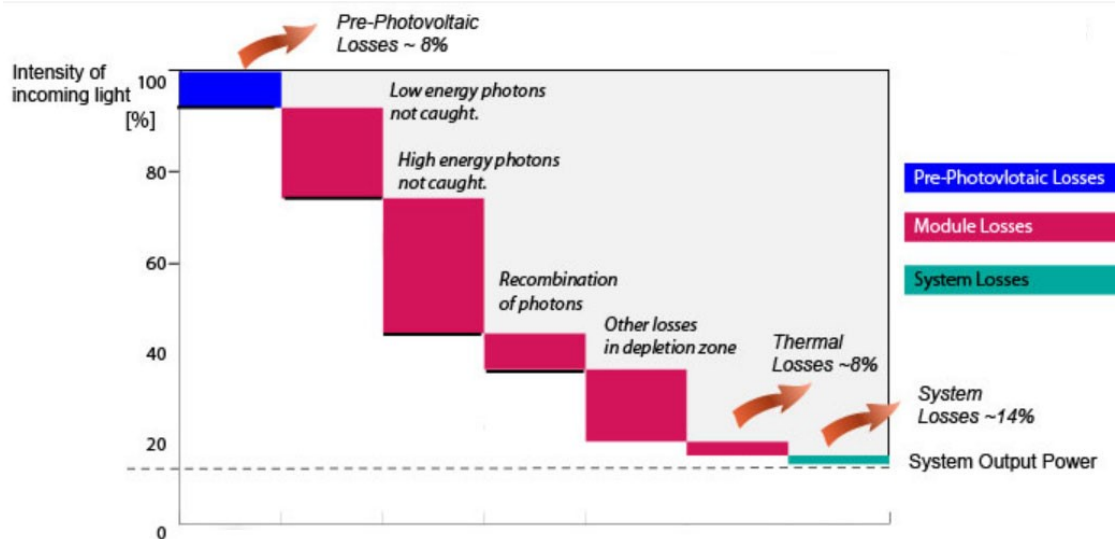

- **Pre-PV losses (~8%):** Shadows, dirt , snow, reflection
- **Module losses (~62%):** Conversion (nominal efficiency), thermal losses
- **System losses (~14%):** Wiring, tracking efficiency (finding maximum power point), inverter efficiency, transformer, O&M (downtime for maintenance is low)

PV energy output calculation (2)

The electricity generated by a PV system (actual energy output) is estimated as

$$E = E_{\text{nom}} * PR = A * r * H * PR$$

E = Actual energy output (kWh)

E_{nom} = **A * r * H** = Nominal energy output (kWh)

A = Total solar panel area (m²)

r = η = Solar panel yield (PV modular efficiency, %)

H = Annual average solar irradiation on tilted panels (shadings not included) (kWh/m²)

PR = Performance ratio, coefficient for losses (range between 0.5 and 0.9, or 0.6 and 0.8 by NREL estimation)

Performance Ratio

- **Performance Ratio (PR):** A very important value to evaluate the quality of a PV installation because it gives the performance of the installation independently of the orientation, inclination of the panel.
- **PR includes all losses.** It quantifies the overall effect of losses on the PV system rated output.
- **Calculation of PR:** p.a. is per annum

$$\text{PR} = \frac{\text{Actual reading of plant output in kWh p.a.}}{\text{Calculated, nominal plant output in kWh p.a.}}$$

$$\text{PR} = E / E_{\text{nom}} = \text{Actual energy output} / (A * r * H)$$

Practice: PR calculation

The performance data for a PV panel is given below.

Determine the performance ratio of the PV panel.

Data

Analysis period: 1 year

Measured average solar irradiation intensity in 1 year: 120 kWh/m^2

Generator area of the PV plant: 10 m^2

Efficiency factor of the PV modules: 15 %

Electrical energy actually exported by plant to grid: 110 kWh

Maximum power point tracking (1)

- The **operating point on an I- V curve** is determined by the **connected electrical load**.
- PV cells operate most efficiently at their **maximum power points**.
- However, **the maximum power point constantly changes** due to **changes in solar irradiance and cell temperature**.
- Hence, some systems use **maximum power point tracking (MPPT)** to **dynamically match the electrical loads to PV output** in order to maximize the performance.
- This function is included in most interactive inverters and some battery charge controllers.

Maximum power point tracking (2)

The **electrical load resistance** required to operate a PV device **at the maximum power point** is calculated as

$$R_{mp} = \frac{V_{mp}}{I_{mp}}$$

R_{mp} = resistance at maximum power point

V_{mp} = maximum power voltage

I_{mp} = maximum power current

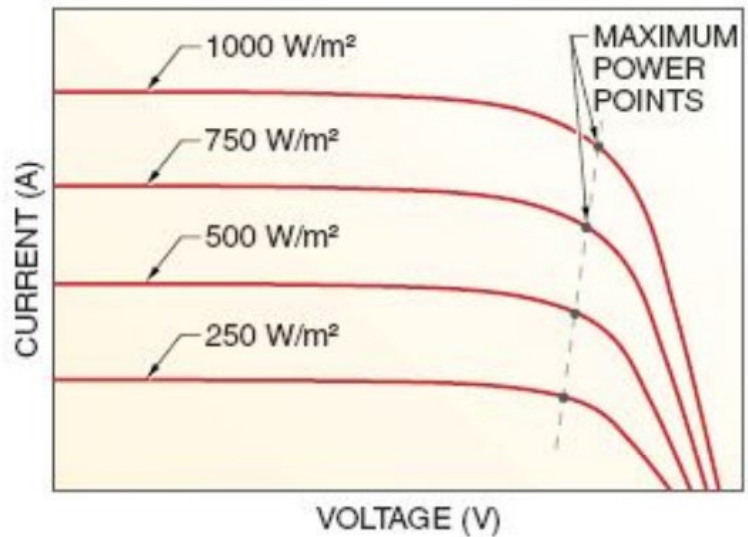

I-V curves for different irradiance levels & maximum power points

→ For tracking a maximum power point, a particular load resistance is required.

Modeling a PV system (1)

- A PV system can be modeled by **a current source in parallel with a diode, in parallel with a resistance, and in series with another resistance** (as shown in the figure below).
- Both series and shunt resistances have a strong effect on the shape of the I- V curve.

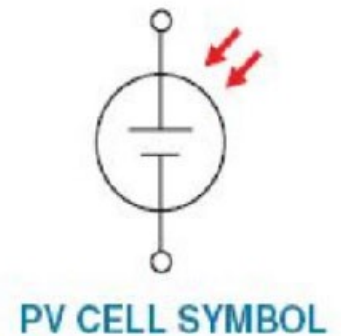
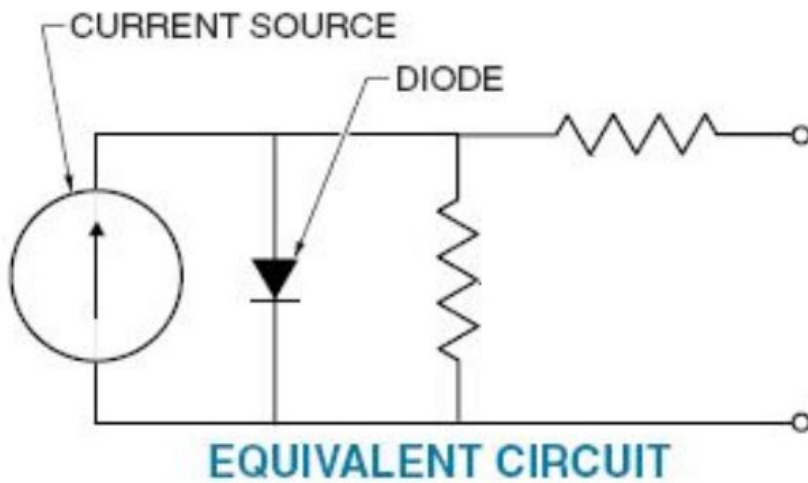

Modeling a PV system (2)

Series resistance impact

- Series resistance includes the resistance of a cell, its electrical contacts, module connections, and system wiring.
- **Increasing series resistance over time can indicate problems** with electrical connections or cell degradation.
- **Increasing series resistance reduces the voltage over the entire I- V curve.**
- Increasing series resistance also **decreases maximum power, fill factor, and efficiency.**

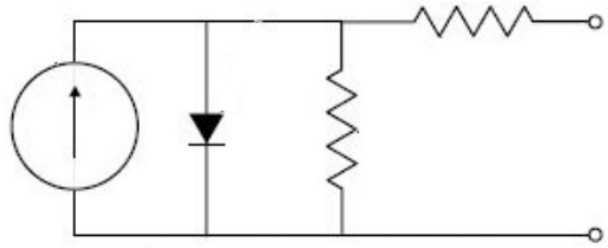

Equivalent circuit of a PV system

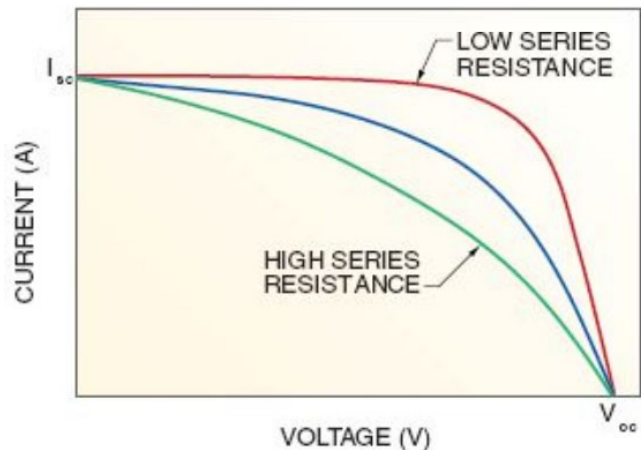

Impact of **series R** on I-V curve

Modeling a PV system (3)

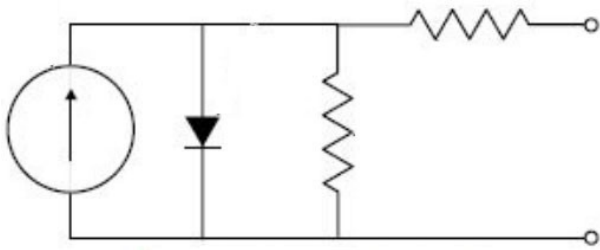

Shunt resistance impact

- Shunt resistance accounts for **leakage currents** within a cell, module, or array.
- **Decreasing shunt resistance reduces fill factor, efficiency, maximum voltage, current, and power**, but **does not affect short-circuit current**.
- Decreasing shunt resistance over time **can indicate short-circuits** between cell circuits and module frames, or ground faults within an array.

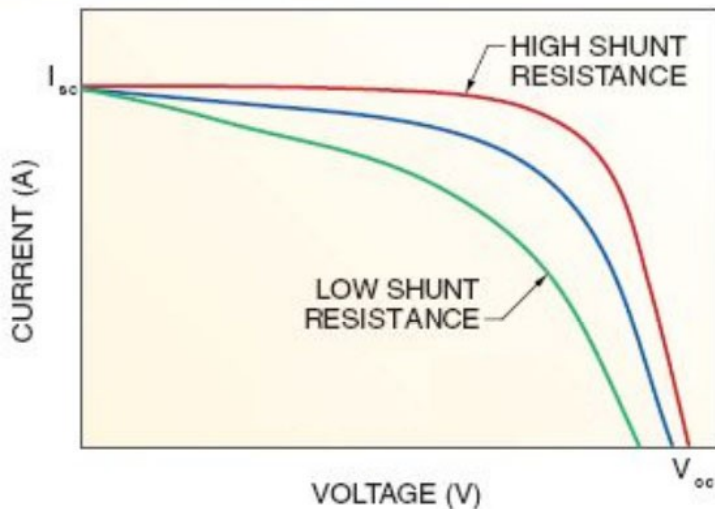

Impact of **shunt R** on I-V curve

Relation between H, I and P (1)

- **Changes in solar irradiance H** have a **small effect on voltage** but a **significant effect on the current** output of PV systems.
- The **current** of a PV system **increases with increasing solar irradiance**. Since the voltage remains nearly the same, the **power also increases**.

$$\frac{H_2}{H_1} = \frac{I_2}{I_1} = \frac{P_2}{P_1}$$

H_2 = solar irradiance 2 (in W/m²)

H_1 = solar irradiance 1 (in W/m²)

I_2 = current at irradiance 2 (in A)

I_1 = current at irradiance 1 (in A)

P_2 = power at irradiance 2 (in W)

P_1 = power at irradiance 1 (in W)

Relation between H, I and P (2)

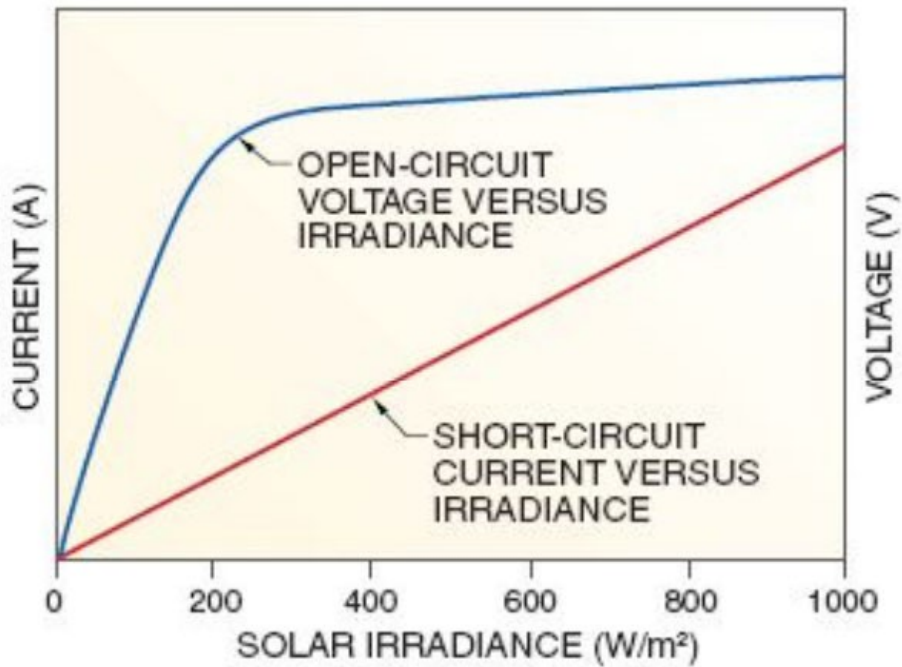

$$\frac{H_2}{H_1} = \frac{I_2}{I_1} = \frac{P_2}{P_1}$$

Voltage does not change much

→ This relationship is usually used to estimate **short-circuit current, maximum power current, and maximum power** when irradiance changes.

Example: Relation between H, I and P

A PV module has a rated short-circuit current of 6 A and a maximum power of 150W at 1000 W/m² of solar irradiance.

What is the **short-circuit current** and the **maximum power** at **600 W/ m² of irradiance**?

Solution:

$$\frac{H_2}{H_1} = \frac{I_2}{I_1} = \frac{P_2}{P_1}$$

$$I_{sc2} = I_{sc1} \times \frac{H_2}{H_1}$$

$$P_{mp2} = P_{mp1} \times \frac{H_2}{H_1}$$

$$I_{sc2} = 6 \times \frac{600}{1000} = 3.6 \text{ A}$$

$$P_{mp2} = 150 \times \frac{600}{1000} = 90 \text{ W}$$

Impact of temperature on I-V curve (1)

- **Cell temperature: Internal temperature at the p-n junction.** It depends on ambient temperature, wind speed, solar irradiance, thermal characteristics of packaging, and the way the cell or module is installed.
- High operating temperatures significantly **reduce voltage output.**
- Current slightly increases with temperature, so the **net result is a decrease in power and efficiency.**
- Long-term high temperatures can lead to **premature degradation** of cells and module encapsulation.

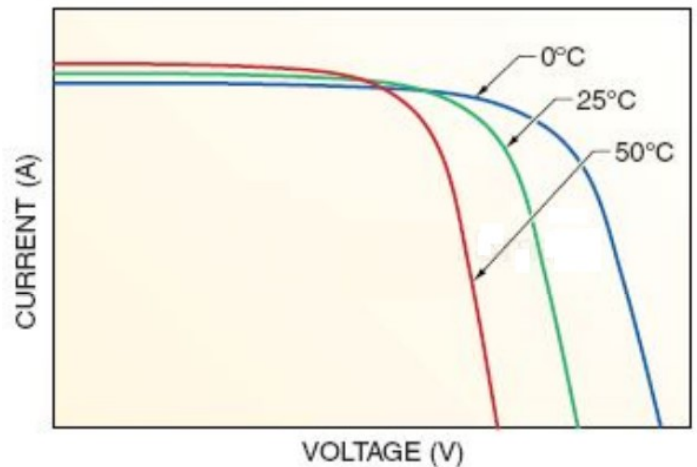

→ Hence, PV modules and arrays should be installed in a manner that allows them to operate as cool as possible.

→ One way is to **raise PV array back surface to expose it to wind for cooling.**

Impact of temperature on I-V curve (2)

Example of bad (upper) and good (lower) PV installation



Temperature-rise coefficient (1)

- **Cell temperature** can be estimated by either **directly measuring** the cell or module surface temperature or **applying the temperature-rise coefficient**.
- This coefficient is used for **estimating the rise in cell temperature above ambient temperature** due to solar irradiance.
- When the **temperature-rise coefficient has been established for a particular installation**, cell temperature under various conditions can be estimated as:

$$T_{cell} = T_{amb} + (C_{T-rise} \times H)$$

T_{cell} = cell temperature (in °C)

T_{amb} = ambient temperature (in °C)

C_{T-rise} = temperature-rise coefficient
(in °C/kW/m²)

H = solar irradiance (in kW/m²)

Temperature-rise coefficient (2)

Example: A rooftop-mounted PV array has a temperature-rise coefficient of **20° C/ kW/ m2**. If the ambient temperature is **30°C** and the solar irradiance is **1100 W/m2**, what is the estimated **cell temperature**?

Solution:

$$T_{cell} = T_{amb} + (C_{T-rise} \times H)$$

$$T_{cell} = 30 + (20 \times 1.1) = 52^{\circ}\text{C}$$

Note:

- For modules with the back surfaces exposed to wind, the temperature-rise coefficient may be about **15 to 20° C/ kW/ m2** (27 to 36° F/ kW/ m2).
- For modules mounted close to or directly on a surface, with the back surface not exposed to wind, the temperature-rise coefficient may be as high as **25 to 30° C/ kW/ m2** (45 to 54° F/ kW/ m2).

Temperature coefficients

Temperature coefficients: Rates of change in voltage, current, or power output from a PV device due to changing cell temperature.

- Temperature coefficients can be expressed as an **absolute change** or a **percentage change** per degree of temperature change.
- Temperature coefficients may be **general or specific** for certain I- V parameters.
- **Note:** A temperature coefficient specific for **open-circuit voltage cannot accurately predict the effects of temperature at other voltages.**
- Typical temperature coefficient values for **crystalline silicon cells** are **$-2.25 \text{ mV}/^\circ\text{C}$** / cell and **$3.70 \text{ }\mu\text{A}/^\circ\text{C}$** / cm^2 .

Conversion of temperature coefficients (1)

Conversion of temperature coefficients for cell to module or array coefficients is as follows. If the coefficient is absolute change:

$$C_V = C_{V-cell} \times n_s$$

$$C_I = C_{I-cell} \times n_p \times A$$

C_V = module or array unit temperature coefficient for voltage (in $V/^\circ C$)

C_{V-cell} = cell unit temperature coefficient for voltage (in $V/^\circ C/cell$)

n_s = number of series-connected cells

C_I = module or array unit temperature coefficient for current (in $A/^\circ C$)

C_{I-cell} = cell unit temperature coefficient for current (in $A/^\circ C/cm^2$)

n_p = number of parallel-connected cell strings

A = individual cell area (in cm^2)

Conversion of temperature coefficients (2)

If the coefficient is percentage change:

C_V = unit temperature coefficient for voltage (in $V/^\circ\text{C}$)

V_{ref} = reference (or rated) voltage (in V)

$C_{\%V}$ = percentage temperature coefficient for voltage (in $^\circ\text{C}$)

C_I = unit temperature coefficient for current (in $A/^\circ\text{C}$)

I_{ref} = reference (or rated) current (in A)

$C_{\%I}$ = percentage temperature coefficient for current (in $^\circ\text{C}$)

C_P = unit temperature coefficient for power (in $W/^\circ\text{C}$)

P_{ref} = reference (or rated) power (in W)

$C_{\%P}$ = percentage temperature coefficient for power (in $^\circ\text{C}$)

$$\begin{aligned}C_V &= V_{ref} \times C_{\%V} \\C_I &= I_{ref} \times C_{\%I} \\C_P &= P_{ref} \times C_{\%P}\end{aligned}$$

Temperature translation of I-V curve

Temperature translations: Use of temperature coefficients to estimate the change in I-V curve (V, I, P) due to cell temperature.

Common translated parameters: V_{oc} , V_{mp} , P_{mp} using reference values at 25°C. Because the cell temperature **effect on current is very small**, it is often ignored.

$$V_{trans} = V_{ref} + ([T_{cell} - T_{ref}] \times C_V)$$

$$P_{trans} = P_{ref} + ([T_{cell} - T_{ref}] \times C_P)$$

V_{trans} = translated voltage at cell temperature (in V)

V_{ref} = reference (or rated) voltage corresponding to T_{ref} (in V)

T_{cell} = cell temperature (in °C)

T_{ref} = reference (or rated) temperature (in °C)

C_V = unit temperature coefficient of voltage (in V/°C)

P_{trans} = translated power at cell temperature (in W)

P_{ref} = reference (or rated) power corresponding to T_{ref} (in W)

C_P = unit temperature coefficient of power (in W/°C)

Practice: Temperature impact on I-V curve

A PV module with **36 series-connected cells** has a **rated $V_{oc} = 21.7V$** and rated power of **130.2 W** under STC.

The manufacturer's temperature coefficient for V_{oc} for individual cells is **$-2.1 \text{ mV}/^\circ\text{C}/ \text{cell}$** .

The ambient temperature is 30°C . The solar irradiance is **$800 \text{ W}/\text{m}^2$** , and temperature-rise coefficient is **$25^\circ\text{C}/ \text{kW}/\text{m}^2$** .

Under these conditions:

- 1) What is the expected open-circuit voltage?
- 2) What is the expected power output?

PV module and array connection (1)

- **PV cells are connected to form modules and modules are connected to form arrays.**
- PV devices are generally **first connected in series to achieve a desired voltage**, forming a string.
- These series strings are **then connected in parallel to build current and power**.
- The same principles are used to build larger systems.

PV module and array connection (2)

Series strings of PV cells to build voltage.

Only PV devices having the **same current output** should be connected in series. → Why?

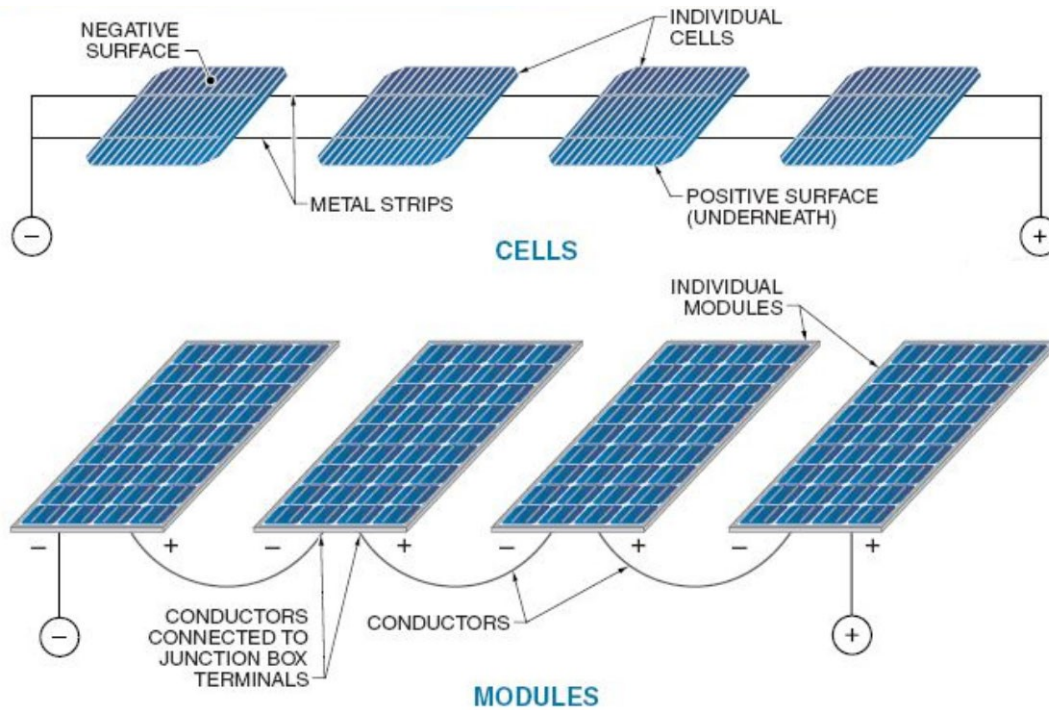

PV module and array connection (3)

Parallel strings of PV cells to build current and power

Parallel connections are not generally used for individual PV devices, especially cells, but for series strings of cells and modules.

Only PV devices having the **same voltage** should be connected in parallel. → Why?

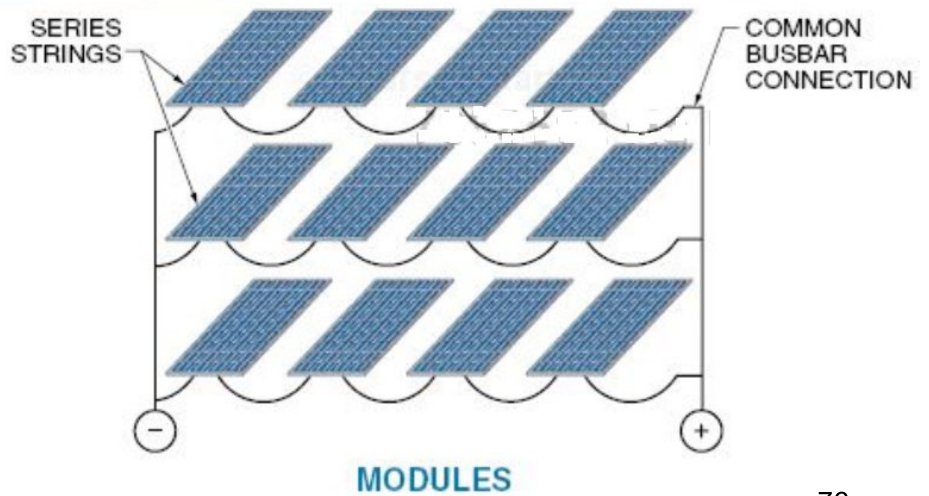
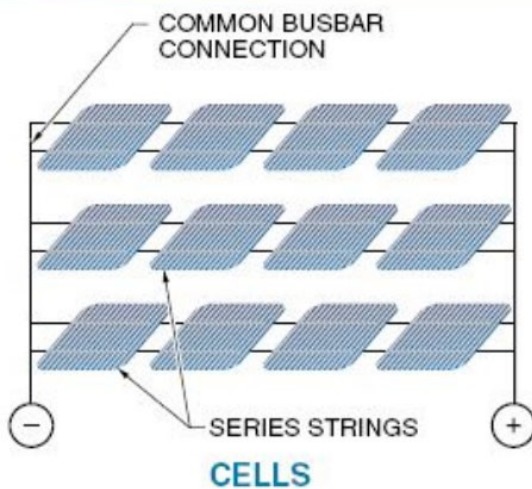

Reverse bias prevention (1)

Reverse bias: Condition where a PV device **operates at negative (reverse) voltage**.

- A reverse-biased device will continue to pass current, but since the voltage is negative, the **device will consume power instead of producing power**.
- Reverse-bias conditions **can occur when a PV cell is open-circuited or shaded**, or when other conditions result in **unequal current output from devices in a series string**.
- **Bypass diodes** (shunt diodes), are used **in parallel with groups of cells or modules** to **prevent a reverse-bias condition**.

Reverse bias prevention (2)

Bypass diodes **allow current to flow around** devices that develop an open-circuit or high-resistance condition.

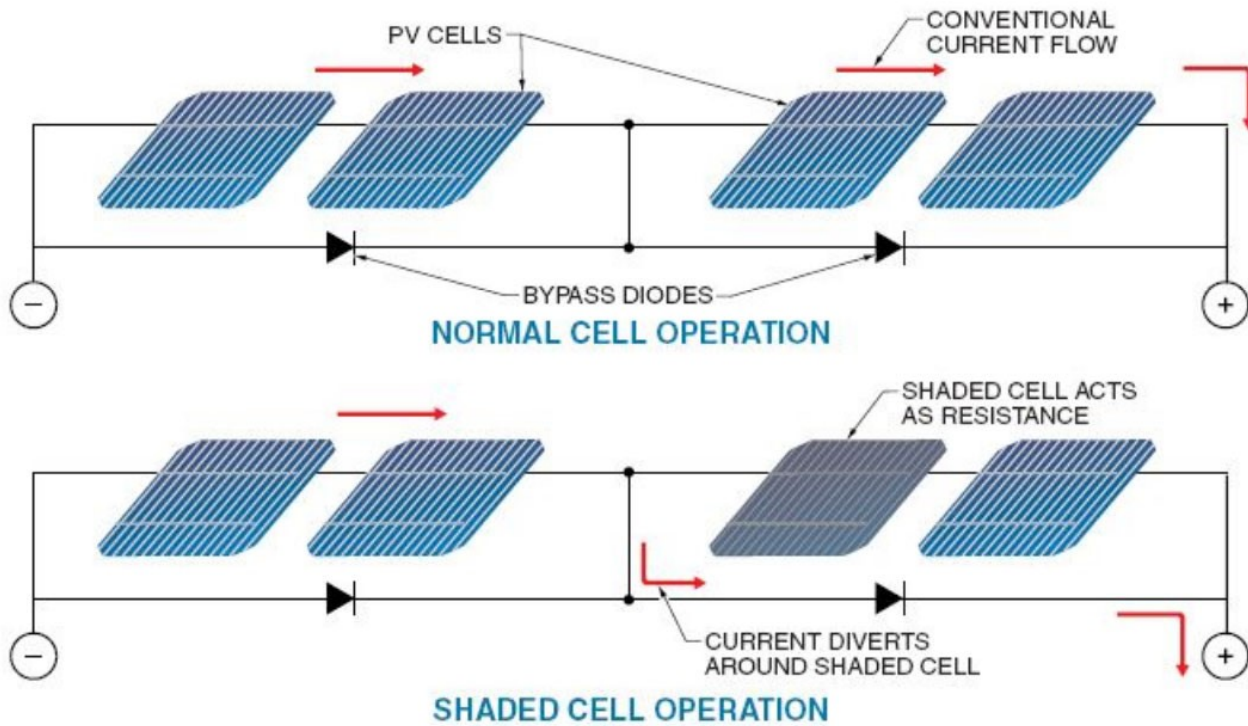

Reverse bias prevention (3)

- **A bypass diode is a diode used to pass current around, rather than through, a group of PV cells.**
- The **current is allowed to pass around groups of cells that are shaded** or develop an open-circuit or other high resistance condition, **preventing discontinuity** of the string.
- This allows the functional cells or modules in the string to continue delivering power. The consequence is that **the string will operate at a lower voltage.**
- Bypass diodes are either **embedded in the module laminate**, (non-serviceable), or are **located in the module junction box**, where they can be inspected and replaced as required.