

- 7) Complete the square to write the equation of the circle in standard form. Then determine the center and radius.

$$x^2 + y^2 + 14x - 14y = -73$$

A) $(x - 7)^2 + (y + 7)^2 = 25$
 $(-7, 7), r = 25$

B) $(x - 7)^2 + (y + 7)^2 = 25$
 $(7, -7), r = 5$

C) $(x + 7)^2 + (y - 7)^2 = 25$
 $(7, -7), r = 25$

D) $(x + 7)^2 + (y - 7)^2 = 25$
 $(-7, 7), r = 5$

- 8) Divide and express the result in standard form.

$$\frac{2i}{1 - 5i}$$

A) $-\frac{5}{13} + \frac{1}{13}i$

B) $\frac{1}{13} - \frac{5}{13}i$

C) $\frac{5}{12} + \frac{1}{12}i$

D) $-\frac{1}{12} + \frac{5}{12}i$

- 9) Solve, using the quadratic formula.

$$x^2 + 6x + 25 = 0$$

A) $\{-3 + 4i\}$

B) $\{-3 \pm 16i\}$

C) $\{-3 \pm 4i\}$

D) $\{-7, 1\}$

- 10) Find the zeros for the polynomial function and give the multiplicity for each zero. State whether the graph crosses the x-axis or touches the x-axis and turns around, at each zero.

$$f(x) = x^3 + x^2 - 12x$$

A) -4, multiplicity 2, touches the x-axis and turns around
3, multiplicity 1, crosses the x-axis

B) 0, multiplicity 1, crosses the x-axis
-4, multiplicity 1, crosses the x-axis
3, multiplicity 1, crosses the x-axis

C) 0, multiplicity 1, touches the x-axis and turns around;
-4, multiplicity 1, touches the x-axis and turns around;
3, multiplicity 1, touches the x-axis and turns around

D) 0, multiplicity 1, crosses the x-axis
4, multiplicity 1, crosses the x-axis
-3, multiplicity 1, crosses the x-axis

- 11) Use synthetic division and the remainder theorem to find the function value.

$$f(x) = x^5 - 2x^4 - 3x^3 + 8; \quad f(4)$$

A) -328

B) 328

C) 28

D) -696

- 12) Find all the zeros of the function using synthetic division.

$$f(x) = x^3 + 8x^2 - x - 8$$

A) $\{1, -1, 8\}$

B) $\{-1, -2, -4\}$

C) $\{1, -2, 4\}$

D) $\{1, -1, -8\}$

- 13) List all possible Rational Zeros.

$$f(x) = -2x^3 + 3x^2 - 2x + 8$$

A) $\pm \frac{1}{2}, \pm 1, \pm 2, \pm 4, \pm 8$

C) $\pm \frac{1}{8}, \pm \frac{1}{4}, \pm \frac{1}{2}, \pm 1, \pm 2, \pm 4, \pm 8$

B) $\pm \frac{1}{4}, \pm \frac{1}{2}, \pm 1, \pm 2, \pm 4, \pm 8$

D) $\pm \frac{1}{2}, \pm 1, \pm 2, \pm 4$

- 14) Solve the polynomial equation, using the Rational Zero Theorem and Descartes Rules of Signs to find the rational zero, then factor or use quadratic formula to solve for the other roots.

$$x^3 - 8x^2 + 19x - 14 = 0$$

A) $\{2, 3 + \sqrt{2}, 3 - \sqrt{2}\}$

C) $\{-2, 6 + \sqrt{2}, 6 - \sqrt{2}\}$

B) $\{1, -1, 14\}$

D) $\{2, 6 + \sqrt{14}, 6 - \sqrt{14}\}$

- 15) Solve the polynomial inequality and graph the solution on the number line.

$$x^2 + 4x \geq 0$$

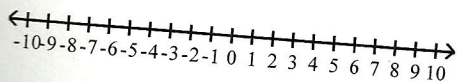

A) $(-\infty, -4] \cup [0, \infty)$

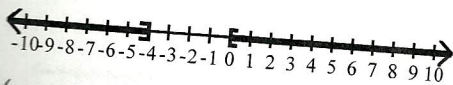

C) $(-\infty, -4]$

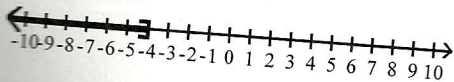

B) $[-4, 0]$

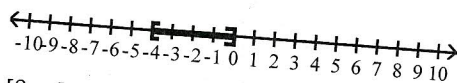

D) $[0, \infty)$

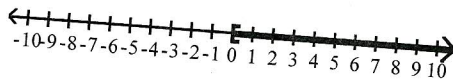

16) Graph the rational function.

$$f(x) = \frac{-4x}{x+2}$$

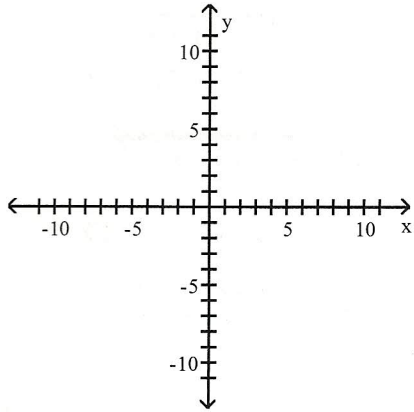

A)

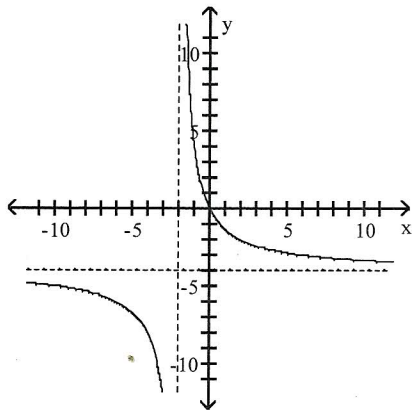

B)

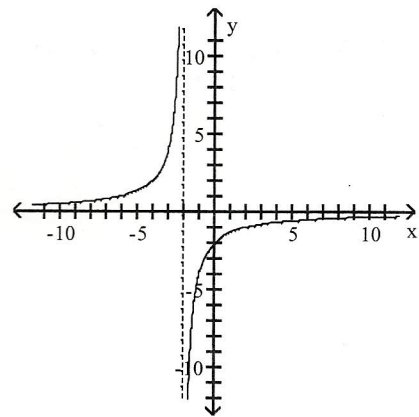

C)

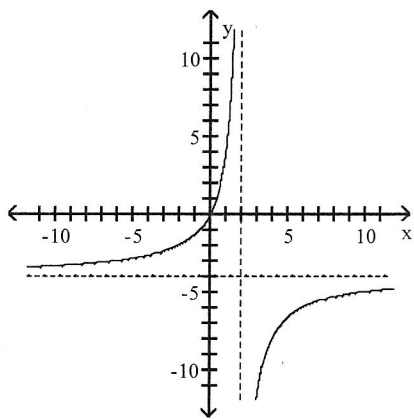

D)

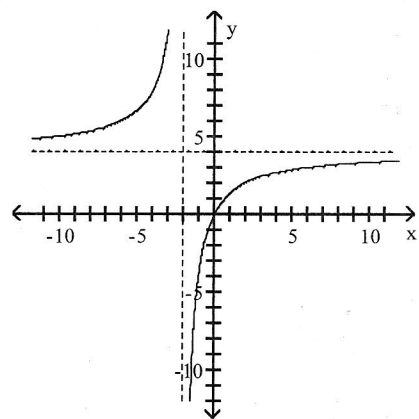

17) Solve the rational inequality and graph on the number line.

21) $\frac{7}{x-2} < 1$

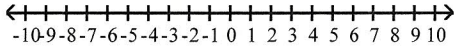

A) $(-\infty, 2]$ or $[9, \infty)$

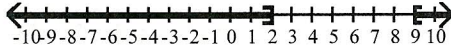

B) $(-\infty, 2)$

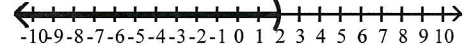

C) $(-\infty, 2)$ or $(9, \infty)$

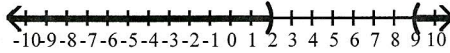

D) $(2, 9)$

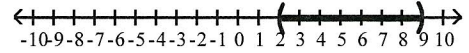

18) Find the accumulated value of an investment of \$5000 at 7% *compounded continuously* for 6 years.

A) \$7709.81

B) \$7609.81

C) \$7503.65

D) \$7100.00

19) The graph of a function is given. Match the function to the graph.

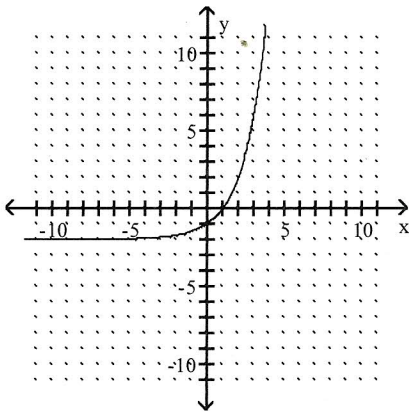

A) $f(x) = 2^x - 2$

B) $f(x) = 2^x$

C) $f(x) = 2^x - 2$

D) $f(x) = 2^x + 2$

20) Find the axis of symmetry, vertex, and relevant intercept(s) for the quadratic function, then graph.

$$f(x) = -x^2 - 8x - 7$$

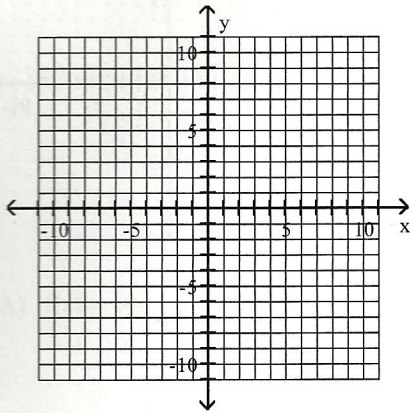

A)

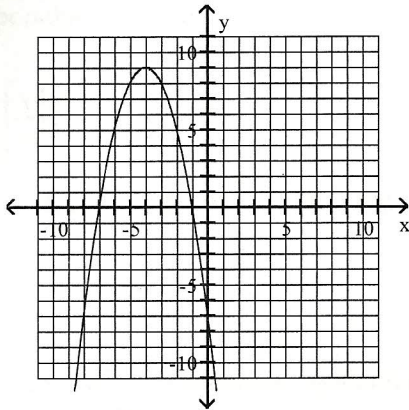

C)

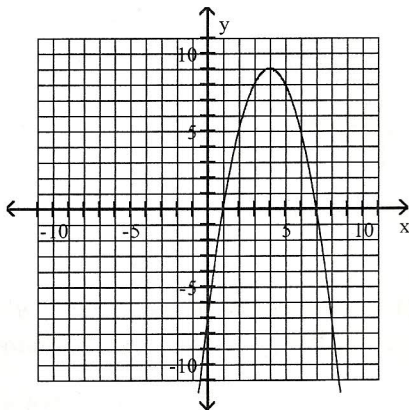

B)

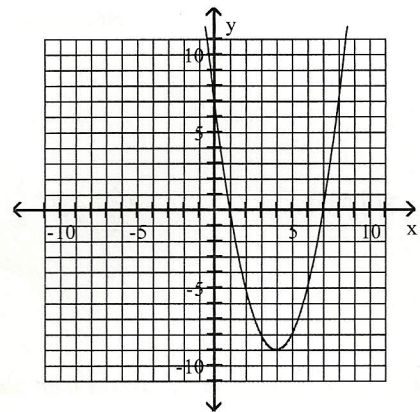

D)

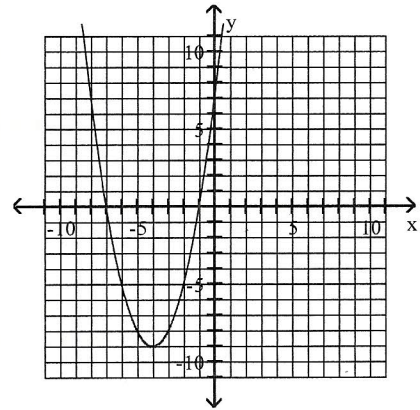

- 21) The graph of a logarithmic function is given. Select the function for the graph from the options.

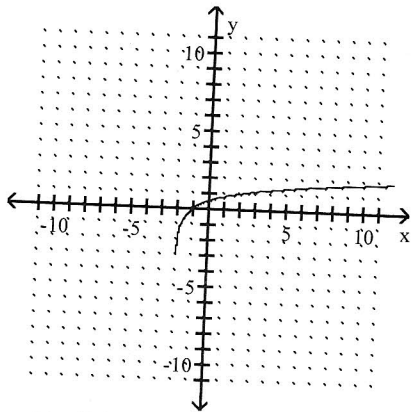

- A) $f(x) = \log_4 x + 2$ B) $f(x) = \log_4 x$ C) $f(x) = \log_4 (x + 2)$ D) $f(x) = \log_4 (x - 2)$

- 22) Use properties of logarithms to expand the logarithmic expression as much as possible. Where possible, evaluate logarithmic expressions without using a calculator.

$$\log_2 \left(\frac{x^2}{y^6} \right)$$

- A) $2 \log_2 x - 6 \log_2 y$ B) $2 \log_2 x + 6 \log_2 y$ C) $\frac{1}{3} \log_2 \left(\frac{x}{y} \right)$ D) $6 \log_2 y - 2 \log_2 x$

- 23) Solve the following exponential equation by expressing each side as a power of the same base and then equating exponents.

$$2^{(7-3x)} = \frac{1}{4}$$

- A) {3} B) $\left\{ \frac{1}{2} \right\}$ C) {1} D) {-3}

- 24) Solve the logarithmic equation. Be sure to reject any value that is not in the domain of the original logarithmic expressions. Give the exact answer.

$$\log 4x = \log 5 + \log (x - 3)$$

- A) $\left\{ \frac{2}{3} \right\}$ B) {15} C) {-15} D) $\left\{ -\frac{5}{3} \right\}$

25) Solve the problem.

The half-life of silicon-32 is 710 years. If 60 grams is present now, how much will be present in 800 years?
(Round your answer to three decimal places.)

A) 0.024

B) 55.492

C) 27.477

D) 0

26) Solve the system by the addition method.

$$3x + 7y = 5$$

$$3x + 2y = 25$$

A) $\{(-11, 7)\}$

B) $\{(-11, 3)\}$

C) $\{(11, -4)\}$

D) $\{(-4, 11)\}$

27) Solve the system by method of your choice.

$$3x + y = 9$$

$$6x + 2y = 18$$

A) $\{(5, -6)\}$

B) $\{(0, 9)\}$

C) $\{(x, y) \mid 3x + y = 9\}$

D) \emptyset

28) Solve the problem.

A cruise boat traveled 72 miles downstream, with the current, in 3 hours. The return trip upstream, against the current, covered the same distance but took 12 hours. Find the average velocity of the current.

A) 24 mph

B) 15 mph

C) 9 mph

D) 39 mph

29) Solve the following system of equations.

$$x - y + 3z = -5$$

$$3x + z = 0$$

$$x + 4y + z = 20$$

A) $\{(0, 0, 5)\}$

B) $\{(0, 5, 0)\}$

C) $\{(5, 0, 0)\}$

D) $\{(0, 5, -5)\}$

30) Solve the problem.

Ms. Adams received a bonus check for \$18,000. She decided to divide the money among three different investments. With some of the money, she purchased a municipal bond paying 5.9% simple interest. She invested twice the amount she paid for the municipal bond in a certificate of deposit paying 4.9% simple interest. Ms. Adams placed the balance of the money in a money market account paying 3.7% simple interest. If Ms. Adams' total interest for one year was \$748.80, how much was placed in each account?

A) municipal bond: \$1550
certificate of deposit: \$3100
money market: \$13,350

B) municipal bond: \$1300
certificate of deposit: \$2600
money market: \$14,100

C) municipal bond: \$2300
certificate of deposit: \$4600
money market: \$11,100

D) municipal bond: \$1800
certificate of deposit: \$3600
money market: \$12,600

MULTIPLE CHOICE. Choose the one alternative that best completes the statement or answers the question.

- 1) Simplify the expression.

$$\frac{\sqrt{56x^4}}{\sqrt{2x}}$$

A) $2|x|\sqrt{x}$

B) $56x^3$

C) $2|x|\sqrt{7x}$

D) $\frac{x^2\sqrt{56}}{2}$

- 2) Multiply or divide, as indicated.

$$\frac{3x^2 + 5x - 28}{2x - 6} \cdot \frac{x^2 - 3x}{9x^2 - 49} \div \frac{7x + 28}{3x^3}$$

A) $\frac{14}{3x^4(3x + 7)}$

B) $\frac{3x^4}{14(3x + 7)}$

C) $\frac{3x^3}{14(3x + 7)}$

D) $\frac{7(x + 4)^2}{6x^2(3x + 7)}$

- 3) Solve the radical equation and check solution(s).

$$-\sqrt{3x - 2} = 4 - x$$

A) $\{-1\}$

B) $\{2, 9\}$

C) $\{9\}$

D) $\{1, 2\}$

- 4) Solve the problem.

Suppose a car rental company charges \$110 for the first day and \$60 for each additional or partial day. Let $S(x)$ represent the cost of renting a car for x days. Find the value of $S(4.5)$.

A) \$270

B) \$320

C) \$380

D) \$350

- 5) Find the composition of the two given functions.

$$f(x) = 17x^2 - 10x, \quad g(x) = 9x - 7$$

$$(f \circ g)(6)$$

A) 153

B) 4961

C) 83

D) 37,083

- 6) Determine which two functions are inverses of each other.

$$f(x) = \frac{x - 6}{3} \quad g(x) = 3x - 6 \quad h(x) = \frac{x + 6}{3}$$

A) $f(x)$ and $h(x)$

B) $f(x)$ and $g(x)$

C) $g(x)$ and $h(x)$

D) None