

1-HYDROGEN-3

HALFLIFE = 12.35 YEARS
 DECAY MODE(S): β^-

	<u>RADIATION</u>	<u>y(i)</u> <u>(Bq-s)⁻¹</u>	<u>E(i)</u> <u>(MeV)</u>	<u>y(i) × E(i)</u>
β^-	1	1.00E 00	5.683E-03*	5.68E-03

LISTED β , ce AND Auger RADIATIONS 5.68E-03
 LISTED RADIATIONS 5.68E-03

* AVERAGE ENERGY (MeV)
 HELIUM-3 DAUGHTER IS STABLE.

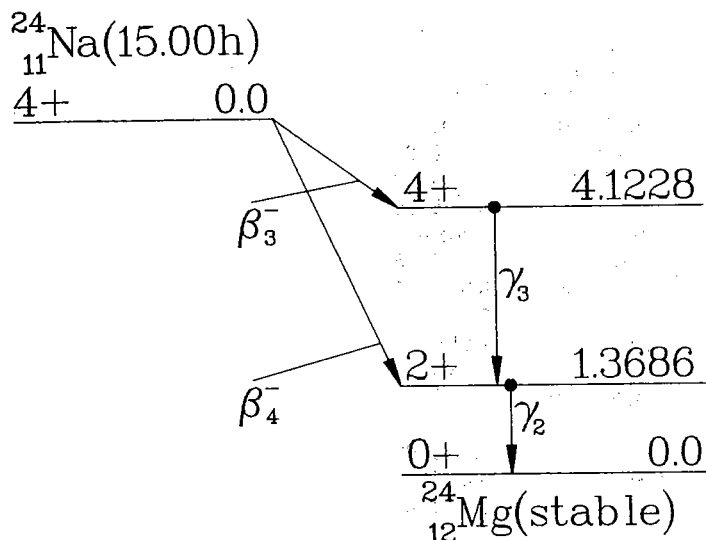

11-SODIUM-24

HALFLIFE = 15 HOURS
DECAY MODE(S): β^-

13-OCT-77

RADIATION	y(i) (Bq-s) ⁻¹	E(i) (MeV)	y(i)×E(i)
β^- 3	9.99E-01	5.537E-01*	5.53E-01
γ 2	1.00E 00	1.369E 00	1.37E 00
γ 3	9.99E-01	2.754E 00	2.75E 00

LISTED X, γ AND γ^\pm RADIATIONS	4.12E 00
OMITTED X, γ AND γ^\pm RADIATIONS**	2.45E-03
LISTED β , ce AND Auger RADIATIONS	5.53E-01
OMITTED β , ce AND Auger RADIATIONS**	1.35E-04
LISTED RADIATIONS	4.67E 00
OMITTED RADIATIONS**	2.59E-03

* AVERAGE ENERGY (MeV)

** EACH OMITTED TRANSITION CONTRIBUTES
<0.100% TO $\sum y(i) \times E(i)$ IN ITS CATEGORY.
MAGNESIUM-24 DAUGHTER IS STABLE.

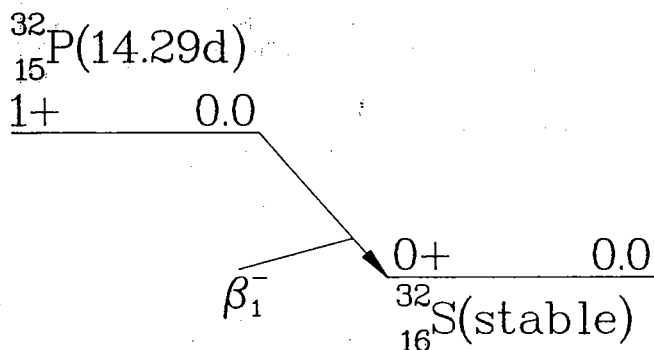

15-PHOSPHORUS-32

HALFLIFE = 14.29 DAYS
DECAY MODE(S): β^-

27-DEC-77

RADIATION	y(i) (Bq-s) ⁻¹	E(i) (MeV)	y(i)×E(i)
β^- 1	1.00E 00	6.947E-01*	6.95E-01

LISTED β , ce AND Auger RADIATIONS	6.95E-01
LISTED RADIATIONS	6.95E-01

* AVERAGE ENERGY (MeV)

SULPHUR-32 DAUGHTER IS STABLE.

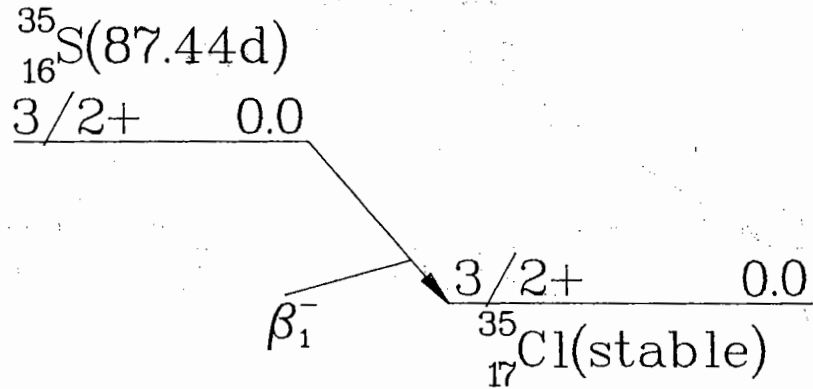

16-SULPHUR-35

HALFLIFE = 87.44 DAYS
 DECAY MODE(S): β^-

27-DEC-77

RADIATION	y(i) (Bq-s) ⁻¹	E(i) (MeV)	y(i)×E(i)
β^- 1	1.00E 00	4.883E-02*	4.88E-02

LISTED β , ce AND Auger RADIATIONS 4.88E-02
 LISTED RADIATIONS 4.88E-02

* AVERAGE ENERGY (MeV)
 CHLORINE-35 DAUGHTER IS STABLE.

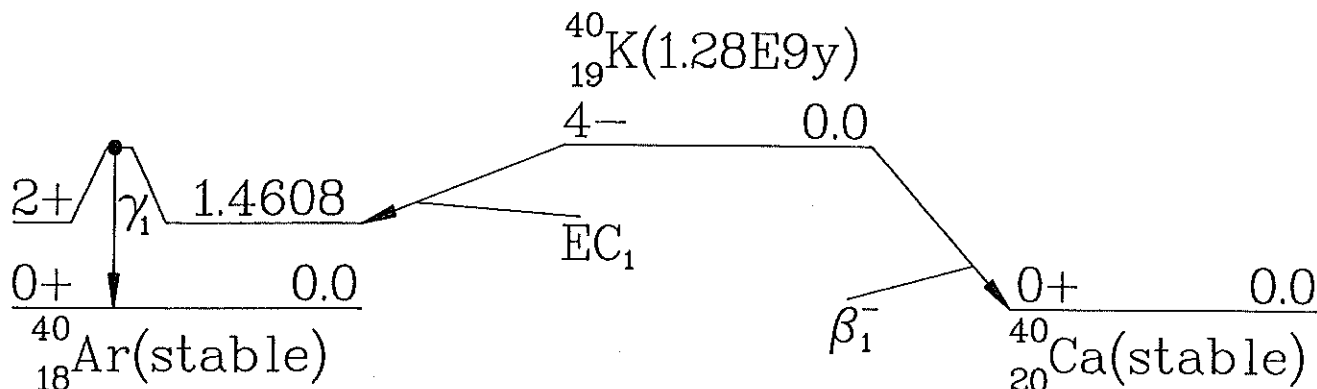

19-POTASSIUM-40

HALFLIFE = 0.128E 10 YEARS
 DECAY MODE(S): β^- , EC

05-MAY-77

RADIATION	y(i) (Bq-s) ⁻¹	E(i) (MeV)	y(i) × E(i)
β 1	8.93E-01	5.850E-01*	5.22E-01
γ 1	1.07E-01	1.461E 00	1.56E-01
ce-K, γ 1	2.82E-06	1.458E 00	4.10E-06
ce-L ₁ , γ 1	2.31E-07	1.460E 00	3.38E-07
ce-L ₂ , γ 1	5.46E-10	1.461E 00	7.97E-10
ce-L ₃ , γ 1	8.26E-10	1.461E 00	1.21E-09
K α_1 X-ray	5.79E-03	2.958E-03	1.71E-05
K α_2 X-ray	2.91E-03	2.956E-03	8.60E-06
K α_3 X-ray	2.87E-10	2.883E-03	8.29E-13
K β_1 X-ray	5.91E-04	3.190E-03	1.89E-06
K β_3 X-ray	3.00E-04	3.190E-03	9.58E-07
L α X-ray	2.63E-05	2.452E-04*	6.45E-09
L β X-ray	3.22E-06	3.076E-04*	9.89E-10
Auger-KLL	6.49E-02	2.640E-03*	1.71E-04
Auger-KLX	8.42E-03	2.919E-03*	2.46E-05
Auger-KXY	4.85E-04	3.174E-03*	1.54E-06
Auger-MXY	1.03E-02	1.587E-05*	1.64E-07

LISTED X, γ AND γ_{\pm} RADIATIONS 1.56E-01
 LISTED β , ce AND Auger RADIATIONS 5.23E-01
 LISTED RADIATIONS 6.79E-01

* AVERAGE ENERGY (MeV)
 CALCIUM-40 DAUGHTER, YIELD 8.93E-01,
 IS STABLE.
 ARGON-40 DAUGHTER, YIELD 1.07E-01,
 IS STABLE.

25-MANGANESE-54

HALFLIFE = 312.5 DAYS
 DECAY MODE(S): EC

06-APR-76

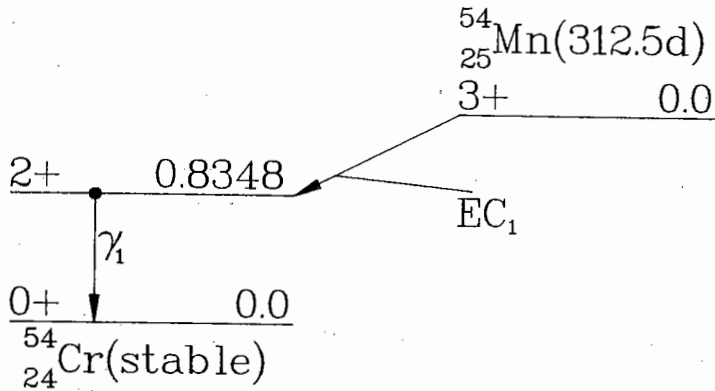

RADIATION	y(i) (Bq-s) ⁻¹	E(i) (MeV)	y(i)×E(i)
γ 1	1.00E 00	8.348E-01	8.35E-01
ce-K, γ 1	2.24E-04	8.288E-01	1.86E-04
ce-L ₁ , γ 1	2.04E-05	8.341E-01	1.70E-05
Auger-KLL	5.27E-01	4.735E-03*	2.50E-03
Auger-KLX	1.13E-01	5.330E-03*	6.01E-04
Auger-KXY	9.12E-03	5.900E-03*	5.38E-05
Auger-LMM	1.45E 00	5.426E-04*	7.87E-04
Auger-LMX	3.82E-02	5.751E-04*	2.20E-05
Auger-MXY	3.10E 00	1.865E-05*	5.78E-05

LISTED X, γ AND γ± RADIATIONS	8.35E-01
OMITTED X, γ AND γ± RADIATIONS**	1.40E-03
LISTED β, ce AND Auger RADIATIONS	4.22E-03
OMITTED β, ce AND Auger RADIATIONS**	3.42E-07
LISTED RADIATIONS	8.39E-01
OMITTED RADIATIONS**	1.40E-03

* AVERAGE ENERGY (MeV)
 ** EACH OMITTED TRANSITION CONTRIBUTES
 <0.100% TO Σy(i)×E(i) IN ITS CATEGORY.
 CHROMIUM-54 DAUGHTER IS STABLE.

27-COBALT-60

HALFLIFE = 5.271 YEARS
 DECAY MODE(S): β

29-MAR-78

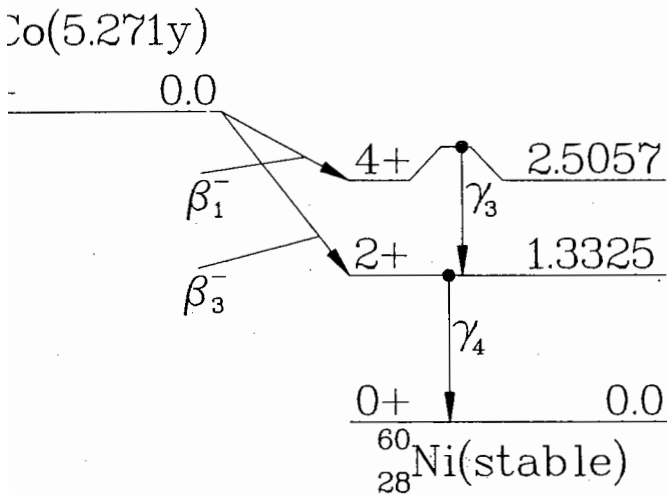

RADIATION	y(i) (Bq-s) ⁻¹	E(i) (MeV)	y(i)×E(i)
β 1	9.99E-01	9.577E-02*	9.57E-02
β 3	8.00E-04	6.258E-01*	5.01E-04
γ 3	9.99E-01	1.173E 00	1.17E 00
ce-K, γ 3	1.50E-04	1.165E 00	1.75E-04
γ 4	1.00E 00	1.332E 00	1.33E 00
ce-K, γ 4	1.14E-04	1.324E 00	1.50E-04

LISTED X, γ AND γ± RADIATIONS	2.50E 00
OMITTED X, γ AND γ± RADIATIONS**	1.14E-04
LISTED β, ce AND Auger RADIATIONS	9.65E-02
OMITTED β, ce AND Auger RADIATIONS**	4.73E-05
LISTED RADIATIONS	2.60E 00
OMITTED RADIATIONS**	1.61E-04

* AVERAGE ENERGY (MeV)
 ** EACH OMITTED TRANSITION CONTRIBUTES
 <0.100% TO Σy(i)×E(i) IN ITS CATEGORY.
 NICKEL-60 DAUGHTER IS STABLE.

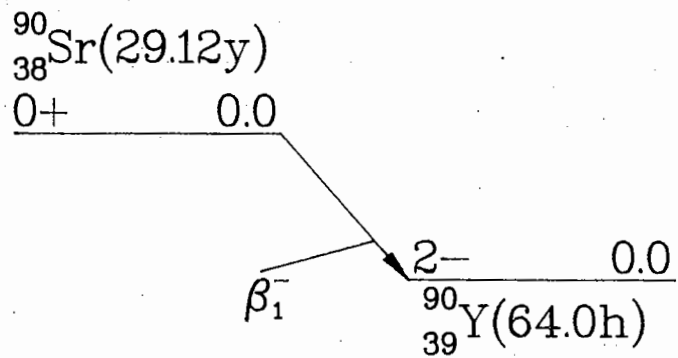

38-STRONTIUM-90

HALFLIFE = 29.12 YEARS
 DECAY MODE(S): β^-

12-DEC-77

RADIATION	y(i) (Bq-s) ⁻¹	E(i) (MeV)	y(i) × E(i)
β^- 1	1.00E 00	1.957E-01*	1.96E-01

LISTED β , ce AND Auger RADIATIONS 1.96E-01
 LISTED RADIATIONS 1.96E-01

* AVERAGE ENERGY (MeV)
 YTTRIUM-90 DAUGHTER IS RADIOACTIVE.

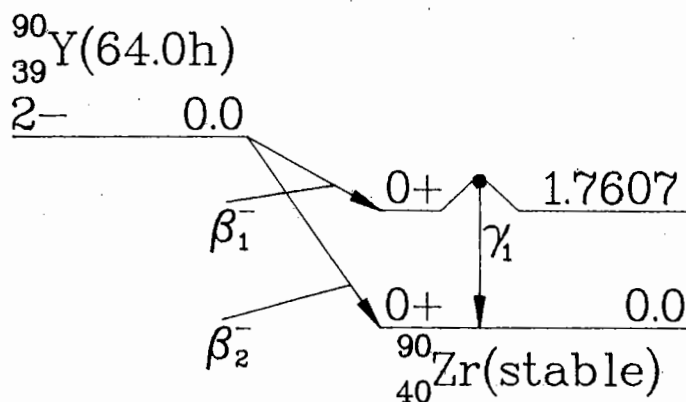

39-YTTRIUM-90

HALFLIFE = 64 HOURS
 DECAY MODE(S): β^-

05-JAN-78

RADIATION	y(i) (Bq-s) ⁻¹	E(i) (MeV)	y(i)×E(i)
β^- 2	1.00E 00	9.348E-01*	9.35E-01
K α_1 X-ray	5.79E-05	1.578E-02	9.13E-07
K α_2 X-ray	3.03E-05	1.569E-02	4.75E-07
K β_1 X-ray	9.55E-06	1.767E-02	1.69E-07
K β_2 X-ray	2.14E-06	1.797E-02	3.85E-08
K β_3 X-ray	4.89E-06	1.765E-02	8.63E-08
L α X-ray	2.29E-06	2.042E-03*	4.67E-09
L β X-ray	1.61E-06	2.130E-03*	3.43E-09

LISTED X, γ AND γ^\pm RADIATIONS	1.69E-06
OMITTED X, γ AND γ^\pm RADIATIONS**	1.25E-09
LISTED β , ce AND Auger RADIATIONS	9.35E-01
OMITTED β , ce AND Auger RADIATIONS**	3.10E-04
LISTED RADIATIONS	9.35E-01
OMITTED RADIATIONS**	3.10E-04

* AVERAGE ENERGY (MeV)
 ** EACH OMITTED TRANSITION CONTRIBUTES
 <0.100% TO $\Sigma y(i) \times E(i)$ IN ITS CATEGORY.
 ZIRCONIUM-90 DAUGHTER IS STABLE.

$^{99}_{42}\text{Mo}(66.0\text{h})$
 $1/2+$ 0.0

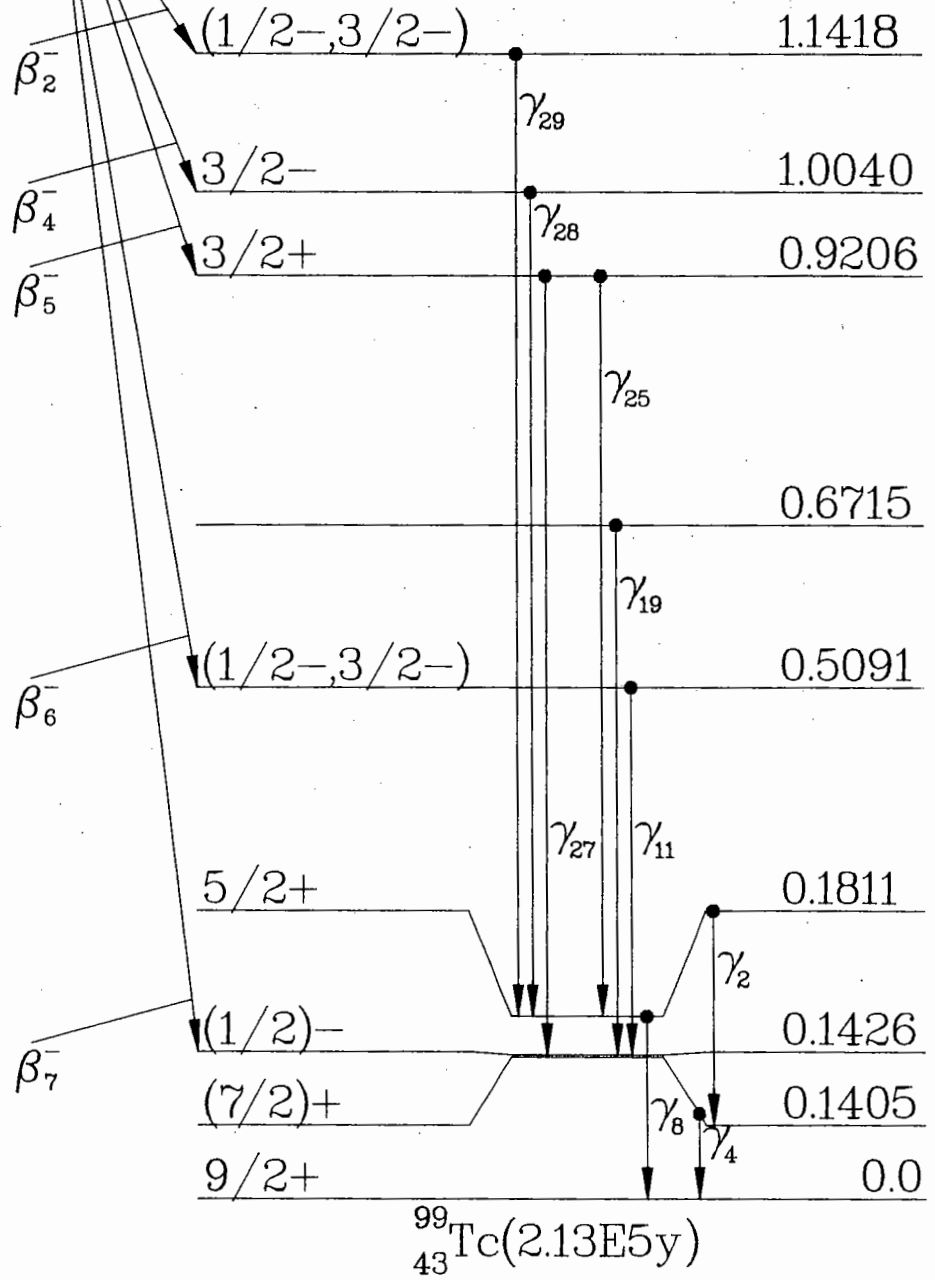

42-MOLYBDENUM-99

HALFLIFE = 66 HOURS
 DECAY MODE(S): β^-

29-MAR-78

<u>RADIATION</u>	<u>y(i)</u> (Bq-s) ⁻¹	<u>E(i)</u> (MeV)	<u>y(i)×E(i)</u>
β^- 5	1.66E-01	1.330E-01*	2.20E-02
β^- 6	1.17E-02	2.895E-01*	3.39E-03
β^- 7	8.20E-01	4.426E-01*	3.63E-01
γ 2	1.16E-02	4.059E-02	4.69E-04
ce-K, γ 2	3.77E-02	1.954E-02	7.38E-04
γ 4	4.95E-02	1.405E-01	6.95E-03
ce-K, γ 4	4.89E-03	1.194E-01	5.84E-04
γ 8	6.06E-02	1.811E-01	1.10E-02
ce-K, γ 8	7.62E-03	1.600E-01	1.22E-03
γ 11	1.19E-02	3.664E-01	4.37E-03
γ 19	5.45E-04	5.288E-01	2.88E-04
γ 24	2.60E-04	6.218E-01	1.61E-04
γ 25	1.22E-01	7.395E-01	9.02E-02
γ 27	4.32E-02	7.779E-01	3.36E-02
γ 28	1.33E-03	8.230E-01	1.09E-03
γ 29	9.76E-04	9.608E-01	9.37E-04
K α_1 X-ray	2.15E-02	1.837E-02	3.95E-04
K α_2 X-ray	1.13E-02	1.825E-02	2.06E-04

LISTED X, γ AND γ^\pm RADIATIONS	1.50E-01
OMITTED X, γ AND γ^\pm RADIATIONS**	4.87E-04
LISTED β , ce AND Auger RADIATIONS	3.91E-01
OMITTED β , ce AND Auger RADIATIONS**	1.33E-03
LISTED RADIATIONS	5.41E-01
OMITTED RADIATIONS**	1.82E-03

* AVERAGE ENERGY (MeV)

** EACH OMITTED TRANSITION CONTRIBUTES
 <0.100% TO $\Sigma y(i) \times E(i)$ IN ITS CATEGORY.

TECHNETIUM-99M DAUGHTER, YIELD 8.76E-01,
 IS RADIOACTIVE.

TECHNETIUM-99 DAUGHTER, YIELD 1.24E-01,
 IS RADIOACTIVE.

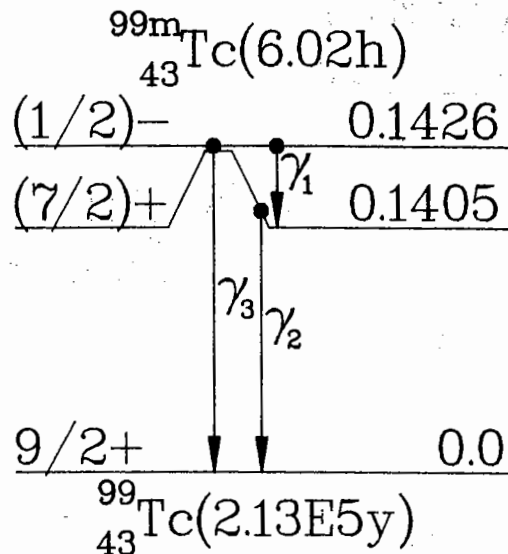

43-TECHNETIUM-99M

HALFLIFE = 6.02 HOURS
 DECAY MODE(S): IT

29-MAR-78

RADIATION	y(i) (Bq-s) ⁻¹	E(i) (MeV)	y(i)×E(i)
ce-M, γ 1	9.14E-01	1.749E-03*	1.60E-03
ce-N ⁺ , γ 1	7.57E-02	2.174E-03*	1.65E-04
γ 2	8.89E-01	1.405E-01	1.25E-01
ce-K, γ 2	8.79E-02	1.194E-01	1.05E-02
ce-L ₁ , γ 2	9.67E-03	1.374E-01	1.33E-03
ce-L ₂ , γ 2	6.10E-04	1.377E-01	8.40E-05
ce-L ₃ , γ 2	3.01E-04	1.378E-01	4.15E-05
ce-M _i , γ 2	1.92E-03	1.400E-01*	2.70E-04
ce-N ⁺ , γ 2	3.71E-04	1.405E-01*	5.21E-05
ce-K, γ 3	6.91E-03	1.216E-01	8.41E-04
ce-L ₁ , γ 3	1.17E-03	1.396E-01	1.63E-04
ce-L ₂ , γ 3	2.43E-04	1.399E-01	3.39E-05
ce-L ₃ , γ 3	7.40E-04	1.400E-01	1.04E-04
ce-M, γ 3	4.19E-04	1.422E-01*	5.97E-05
Kα ₁ X-ray	4.03E-02	1.837E-02	7.39E-04
Kα ₂ X-ray	2.12E-02	1.825E-02	3.86E-04
Kβ ₁ X-ray	6.88E-03	2.062E-02	1.42E-04
Auger-KLL	1.45E-02	1.535E-02*	2.23E-04
Auger-KLX	5.76E-03	1.777E-02*	1.02E-04
Auger-LMM	7.10E-02	2.053E-03*	1.46E-04
Auger-LMX	3.05E-02	2.468E-03*	7.53E-05
Auger-MXY	1.11E 00	4.090E-04*	4.54E-04

LISTED X, γ AND γ± RADIATIONS	1.26E-01
OMITTED X, γ AND γ± RADIATIONS**	1.58E-04
LISTED β, ce AND Auger RADIATIONS	1.62E-02
OMITTED β, ce AND Auger RADIATIONS**	3.88E-05
LISTED RADIATIONS	1.42E-01
OMITTED RADIATIONS**	1.96E-04

* AVERAGE ENERGY (MeV)

** EACH OMITTED TRANSITION CONTRIBUTES
 <0.100% TO Σy(i)×E(i) IN ITS CATEGORY.

TECHNETIUM-99 DAUGHTER IS RADIOACTIVE.

$^{99}_{43}\text{Tc}(2.13\text{E}5\text{y})$
 $9/2+$ 0.0

β_1^- \swarrow
 $5/2+$ 0.0
 $^{99}_{44}\text{Ru}(\text{stable})$

43-TECHNETIUM-99

HALFLIFE = 213000 YEARS

12-DEC-77

DECAY MODE(S): β^-

RADIATION	$y(i)$ (Bq-s) ⁻¹	$E(i)$ (MeV)	$y(i) \times E(i)$
β^- 1	1.00E 00	1.013E-01*	1.01E-01

LISTED β , ce AND Auger RADIATIONS

1.01E-01

LISTED RADIATIONS

1.01E-01

* AVERAGE ENERGY (MeV)

RUTHENIUM-99 DAUGHTER IS STABLE.

$^{131}_{53}\text{I}(8.04\text{d})$
 $7/2+$ 0.0

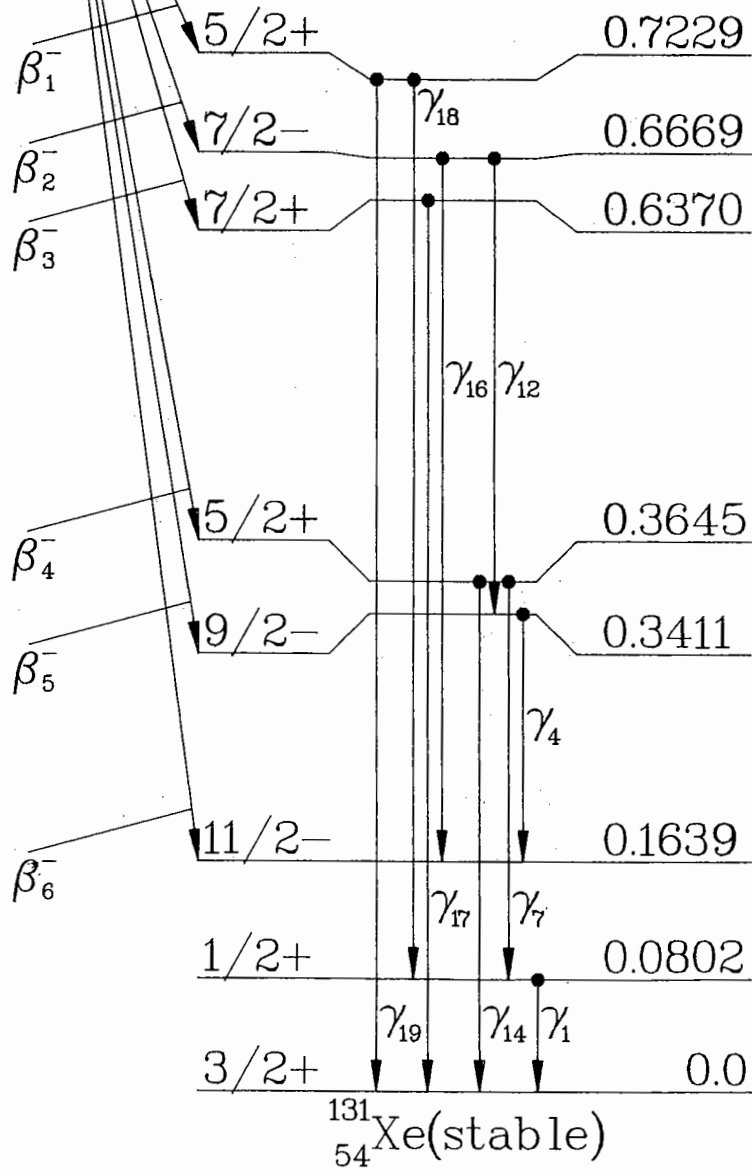

53-IODINE-131

HALFLIFE = 8.04 DAYS

21-JAN-76

DECAY MODE(S): β^-

<u>RADIATION</u>	<u>y(i)</u> <u>(Bq-s)⁻¹</u>	<u>E(i)</u> <u>(MeV)</u>	<u>y(i)×E(i)</u>
β^- 1	2.13E-02	6.935E-02*	1.48E-03
β^- 2	6.20E-03	8.693E-02*	5.39E-04
β^- 3	7.36E-02	9.660E-02*	7.11E-03
β^- 4	8.94E-01	1.915E-01*	1.71E-01
β^- 6	4.20E-03	2.832E-01*	1.19E-03
γ 1	2.62E-02	8.018E-02	2.10E-03
ce-K, γ 1	3.63E-02	4.562E-02	1.66E-03
ce-L ₁ , γ 1	4.30E-03	7.473E-02	3.21E-04
γ 4	2.65E-03	1.772E-01	4.70E-04
γ 7	6.06E-02	2.843E-01	1.72E-02
ce-K, γ 7	2.48E-03	2.497E-01	6.20E-04
γ 12	2.51E-03	3.258E-01	8.18E-04
γ 14	8.12E-01	3.645E-01	2.96E-01
ce-K, γ 14	1.55E-02	3.299E-01	5.10E-03
ce-L ₁ , γ 14	1.71E-03	3.590E-01	6.13E-04
γ 16	3.61E-03	5.030E-01	1.82E-03
γ 17	7.27E-02	6.370E-01	4.63E-02
γ 18	2.20E-03	6.427E-01	1.41E-03
γ 19	1.80E-02	7.229E-01	1.30E-02
K α_1 X-ray	2.59E-02	2.978E-02	7.72E-04
K α_2 X-ray	1.40E-02	2.946E-02	4.12E-04

LISTED X, γ AND γ^\pm RADIATIONS	3.80E-01
OMITTED X, γ AND γ^\pm RADIATIONS**	1.09E-03
LISTED β , ce AND Auger RADIATIONS	1.90E-01
OMITTED β , ce AND Auger RADIATIONS**	1.86E-03
LISTED RADIATIONS	5.70E-01
OMITTED RADIATIONS**	2.95E-03

* AVERAGE ENERGY (MeV)

** EACH OMITTED TRANSITION CONTRIBUTES
<0.100% TO $\Sigma y(i) \times E(i)$ IN ITS CATEGORY.XENON-131M DAUGHTER, YIELD 1.11E-02,
IS RADIOACTIVE.XENON-131 DAUGHTER, YIELD 9.889E-01,
IS STABLE.

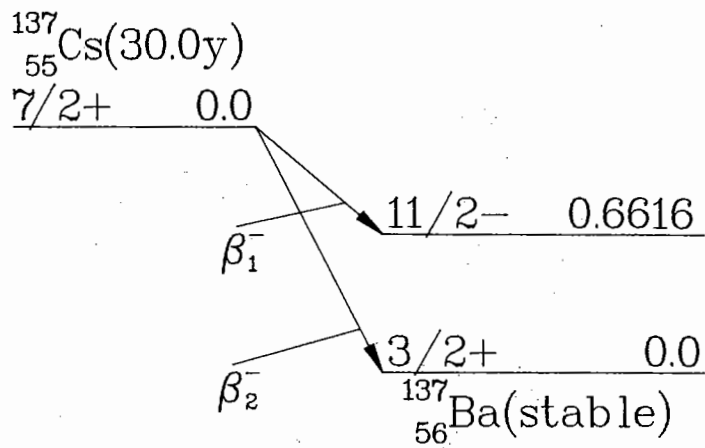

55-CESIUM-137

HALFLIFE = 30 YEARS
 DECAY MODE(S): β^-

04-MAY-77

RADIATION	y(i) (Bq-s) ⁻¹	E(i) (MeV)	y(i)×E(i)
β^- 1	9.46E-01	1.734E-01*	1.64E-01
β^- 2	5.40E-02	4.246E-01*	2.29E-02

LISTED β , ce AND Auger RADIATIONS 1.87E-01
 LISTED RADIATIONS 1.87E-01

* AVERAGE ENERGY (MeV)
 BARIUM-137M DAUGHTER, YIELD 9.46E-01,
 IS RADIOACTIVE.
 BARIUM-137 DAUGHTER, YIELD 5.40E-02,
 IS STABLE.

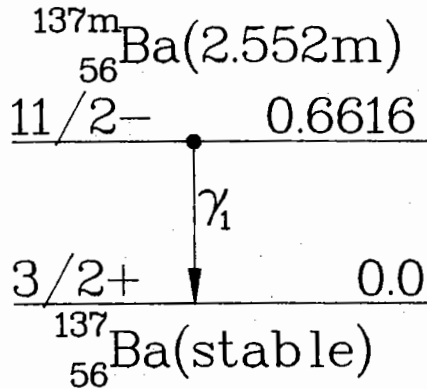

56-BARIUM-137M

HALFLIFE = 2.552 MINUTES
 DECAY MODE(S): IT

04-MAY-77

RADIATION	y(i) (Bq-s) ⁻¹	E(i) (MeV)	y(i)×E(i)				
γ 1	8.98E-01	6.616E-01	5.94E-01	Auger-MXY	1.49E-01	9.276E-04*	1.38E-04
ce-K, γ 1	8.32E-02	6.242E-01	5.19E-02				
ce-L ₁ , γ 1	1.19E-02	6.557E-01	7.80E-03	LISTED X, γ AND γ± RADIATIONS			5.96E-01
ce-L ₂ , γ 1	1.69E-03	6.560E-01	1.11E-03	OMITTED X, γ AND γ± RADIATIONS**			5.68E-04
ce-L ₃ , γ 1	1.39E-03	6.564E-01	9.10E-04	LISTED β, ce AND Auger RADIATIONS			6.51E-02
ce-M, γ 1	3.18E-03	6.606E-01*	2.10E-03	OMITTED β, ce AND Auger RADIATIONS**			3.96E-05
ce-N ⁺ , γ 1	9.02E-04	6.616E-01*	5.97E-04	LISTED RADIATIONS			6.61E-01
Kα ₁ X-ray	3.92E-02	3.219E-02	1.26E-03	OMITTED RADIATIONS**			6.07E-04
Kα ₂ X-ray	2.13E-02	3.182E-02	6.78E-04				
Auger-KLL	5.35E-03	2.618E-02*	1.40E-04	* AVERAGE ENERGY (MeV)			
Auger-KLX	2.53E-03	3.075E-02*	7.79E-05	** EACH OMITTED TRANSITION CONTRIBUTES			
Auger-LMM	4.76E-02	3.577E-03*	1.70E-04	<0.100% TO Σy(i)×E(i) IN ITS CATEGORY.			
Auger-LMX	2.78E-02	4.531E-03*	1.26E-04	BARIUM-137 DAUGHTER IS STABLE.			

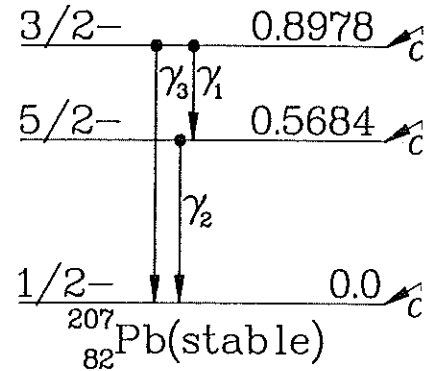
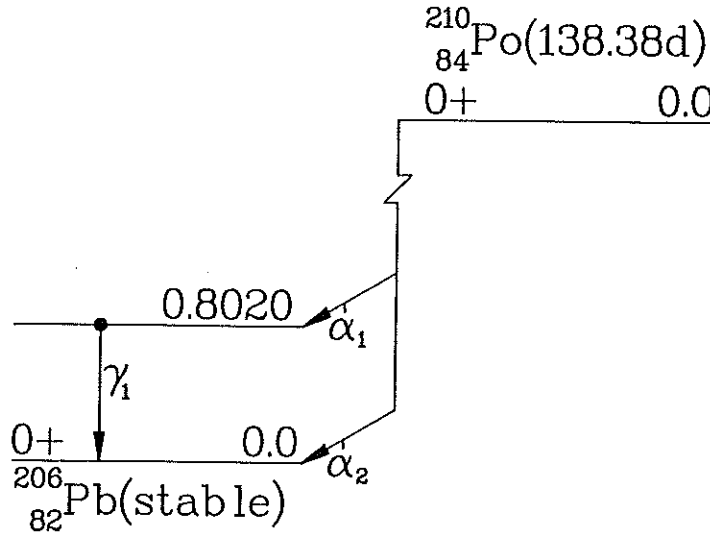

84-POLONIUM-210

84-POLONIUM

HALFLIFE = 138.38 DAYS
DECAY MODE(S): α

27-DEC-77

HALFLIFE = 0.516 SECONDS
DECAY MODE(S): α

RADIATION	y(i) (Bq-s) ⁻¹	E(i) (MeV)	y(i)×E(i)
α 2	1.00E 00	5.297E 00	5.30E 00
α recoil	1.00E 00	1.029E-01	1.03E-01
γ 1	1.06E-05	8.020E-01	8.50E-06
ce-K, γ 1	8.59E-08	7.140E-01	6.13E-08
ce-L ₁ , γ 1	1.25E-08	7.861E-01	9.86E-09
ce-L ₂ , γ 1	4.79E-09	7.868E-01	3.77E-09
ce-L ₃ , γ 1	1.41E-09	7.890E-01	1.11E-09
ce-M, γ 1	4.30E-09	7.989E-01*	3.43E-09
ce-N ⁺ , γ 1	1.63E-09	8.020E-01*	1.31E-09
Auger-KLL	1.67E-09	5.825E-02*	9.70E-11
Auger-LMM	3.10E-08	8.155E-03*	2.53E-10
Auger-LMX	2.03E-08	1.078E-02*	2.18E-10
Auger-MXY	1.28E-07	2.915E-03*	3.74E-10

LISTED X, γ AND γ_{\pm} RADIATIONS 8.50E-06
 OMITTED X, γ AND γ_{\pm} RADIATIONS** 6.76E-09
 LISTED β , ce AND Auger RADIATIONS 8.18E-08
 OMITTED β , ce AND Auger RADIATIONS** 1.38E-10
 LISTED α AND α recoil RADIATIONS 5.40E 00
 OMITTED α AND α recoil RADIATIONS** 4.92E-05
 LISTED RADIATIONS 5.40E 00
 OMITTED RADIATIONS** 4.92E-05

* AVERAGE ENERGY (MeV)
 ** EACH OMITTED TRANSITION CONTRIBUTES
 <0.100% TO $\sum y(i) \times E(i)$ IN ITS CATEGORY.
 LEAD-206 DAUGHTER IS STABLE.

RADIATION	y(i) (Bq-s) ⁻¹
α 1	5.37E-03
α recoil	5.37E-03
α 2	5.46E-03
α recoil	5.46E-03
α 3	9.89E-01
α recoil	9.89E-01
γ 1	3.24E-05
ce-K, γ 1	7.94E-06
ce-L ₁ , γ 1	1.22E-06
γ 2	5.40E-03
ce-K, γ 2	8.59E-05
ce-L ₁ , γ 2	1.27E-05
ce-L ₂ , γ 2	8.46E-06
ce-L ₃ , γ 2	2.91E-06
ce-M, γ 2	5.87E-06
ce-N ⁺ , γ 2	1.94E-06
γ 3	5.24E-03
ce-K, γ 3	1.06E-04
ce-L ₁ , γ 3	1.60E-05
ce-L ₂ , γ 3	1.44E-06
ce-M, γ 3	3.89E-06
ce-N ⁺ , γ 3	1.50E-06
Auger-KLL	3.87E-06
Auger-LMM	7.18E-05
Auger-LMX	4.69E-05
Auger-MXY	2.98E-04

LISTED X, γ AND γ_{\pm} RADIATIONS
 OMITTED X, γ AND γ_{\pm} RADIATIONS**
 LISTED β , ce AND Auger RADIATIONS
 OMITTED β , ce AND Auger RADIATIONS**
 LISTED α AND α recoil RADIATIONS
 LISTED RADIATIONS
 OMITTED RADIATIONS**

* AVERAGE ENERGY (MeV)
 ** EACH OMITTED TRANSITION CONTRIBUTES

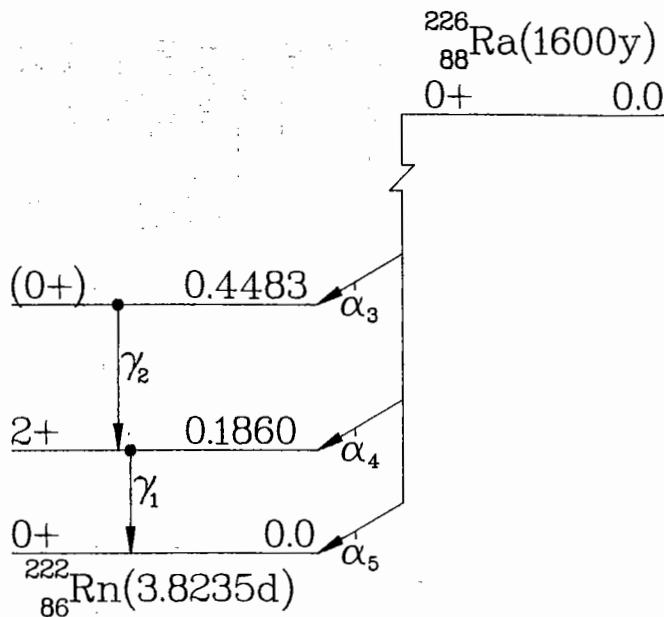

88-RADIUM-226

HALFLIFE = 1600 YEARS
 DECAY MODE(S): α

27-DEC-77

RADIATION	y(i) (Bq-s) ⁻¹	E(i) (MeV)	y(i)×E(i)
α 4	5.55E-02	4.602E 00	2.55E-01
α recoil	5.55E-02	8.297E-02	4.60E-03
α 5	9.44E-01	4.785E 00	4.52E 00
α recoil	9.44E-01	8.626E-02	8.15E-02
γ 1	3.28E-02	1.860E-01	6.10E-03
ce-K, γ 1	6.34E-03	8.759E-02	5.55E-04
ce-L ₁ , γ 1	1.08E-03	1.679E-01	1.81E-04
ce-L ₂ , γ 1	7.00E-03	1.687E-01	1.18E-03
ce-L ₃ , γ 1	3.99E-03	1.714E-01	6.84E-04
ce-M, γ 1	3.21E-03	1.825E-01*	5.86E-04
ce-N ⁺ , γ 1	1.12E-03	1.860E-01*	2.08E-04
γ 2	5.40E-05	2.623E-01	1.42E-05
K α ₁ X-ray	2.98E-03	8.378E-02	2.49E-04
K α ₂ X-ray	1.79E-03	8.107E-02	1.45E-04
K β ₁ X-ray	6.79E-04	9.487E-02	6.44E-05
K β ₂ X-ray	3.36E-04	9.771E-02	3.29E-05
K β ₃ X-ray	3.55E-04	9.424E-02	3.34E-05
L α X-ray	2.53E-03	1.171E-02*	2.96E-05
L β X-ray	4.05E-03	1.428E-02*	5.78E-05
L γ X-ray	9.04E-04	1.688E-02*	1.53E-05
Auger-KLL	1.07E-04	6.452E-02*	6.89E-06
Auger-KLX	6.08E-05	7.826E-02*	4.76E-06
Auger-LMM	5.30E-03	9.327E-03*	4.95E-05
Auger-LMX	3.54E-03	1.230E-02*	4.36E-05
Auger-LXY	6.04E-04	1.462E-02*	8.84E-06
Auger-MXY	2.46E-02	3.274E-03*	8.04E-05
ΔE	6.89E-03	6.534E-04*	4.50E-06

LISTED X, γ AND γ_{\pm} RADIATIONS	6.74E-03
OMITTED X, γ AND γ_{\pm} RADIATIONS**	1.11E-05
LISTED β , ce AND Auger RADIATIONS	3.59E-03
OMITTED β , ce AND Auger RADIATIONS**	3.62E-06
LISTED α AND α recoil RADIATIONS	4.86E 00
OMITTED α AND α recoil RADIATIONS**	3.42E-04
LISTED RADIATIONS	4.87E 00
OMITTED RADIATIONS**	3.56E-04

* AVERAGE ENERGY (MeV)

** EACH OMITTED TRANSITION CONTRIBUTES

<0.100% TO $\sum y(i) \times E(i)$ IN ITS CATEGORY.

RADON-222 DAUGHTER IS RADIOACTIVE.