

6

Cellular Respiration: Obtaining Energy from Food

CHAPTER CONTENTS

- Energy Flow and Chemical Cycling in the Biosphere 92
- Cellular Respiration: Aerobic Harvest of Food Energy 94
- Fermentation: Anaerobic Harvest of Food Energy 101

Why Cellular Respiration Matters

You can survive for weeks without eating and days without drinking, but you can only live for minutes without breathing. Why? Because every cell in your body relies on the energy created by using oxygen to break down glucose during the process of cellular respiration.

YOU HAVE SOMETHING IN COMMON WITH A SPORTS CAR: YOU BOTH REQUIRE AN AIR INTAKE SYSTEM TO BURN FUEL EFFICIENTLY.

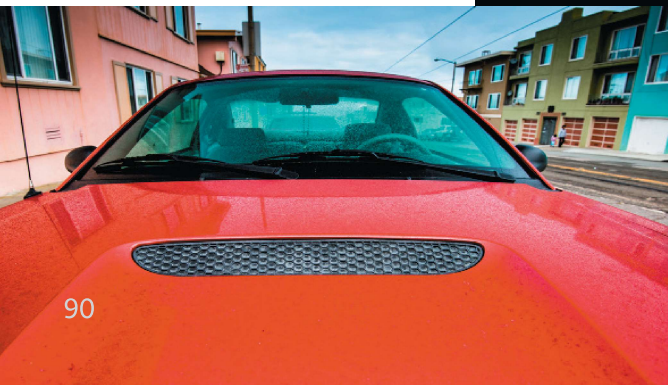

THE METABOLIC PROCESSES THAT PRODUCE ACID IN YOUR MUSCLES AFTER A HARD WORKOUT ARE SIMILAR TO THE PROCESSES THAT PRODUCE PEPPERONI, SOY SAUCE, YOGURT, AND BREAD.



THE CELLS OF YOUR BRAIN BURN THROUGH A QUARTER POUND OF GLUCOSE EACH DAY.

CHAPTER THREAD

Exercise Science

BIOLOGY AND SOCIETY Getting the Most Out of Your Muscles 91

THE PROCESS OF SCIENCE What Causes Muscle Burn? 102

EVOLUTION CONNECTION The Importance of Oxygen 103



BIOLOGY AND SOCIETY Exercise Science

Getting the Most Out of Your Muscles

Serious athletes train extensively to reach the peak of their physical potential. A key aspect of athletic conditioning involves increasing aerobic capacity, the ability of the heart and lungs to deliver oxygen to body cells. For many endurance athletes, such as long-distance runners or cyclists, the rate at which oxygen is provided to working muscles is the limiting factor in their performance.

Why is oxygen so important? Whether you are exercising or just going about your daily tasks, your muscles need a continuous supply of energy to perform work. Muscle cells obtain this energy from the sugar glucose through a series of chemical reactions that depend upon a constant input of oxygen (O_2). Therefore, to keep moving, your body needs a steady supply of O_2 . When there is enough oxygen reaching your cells to support their energy needs, metabolism is said to be aerobic. As your muscles work harder, you breathe faster and more deeply to inhale O_2 . If you continue to pick up the pace, you will approach your aerobic capacity, the maximum rate at which O_2 can be taken in and used by your muscle cells and therefore the most strenuous exercise that your body can maintain aerobically. Exercise scientists can use oxygen-monitoring equipment to precisely determine the maximum possible aerobic output for any given person. Such data allow a well-trained athlete to stay within aerobic limits, ensuring the maximum possible output—in other words, his or her best effort.

If you work even harder and exceed your aerobic capacity, the demand for oxygen in your muscles will outstrip your body's ability to deliver it; metabolism then becomes anaerobic. With insufficient O_2 , your muscle cells switch to an “emergency mode” in which they break down glucose very inefficiently and produce lactic acid as a by-product. As lactic acid and other wastes accumulate, muscle activity is impaired. Your muscles can work under these conditions for only a few minutes before they give out. When this happens (sometimes called “hitting the wall”), your muscles cannot function, and you will likely collapse, unable to even stand.

Every living organism depends on processes that provide energy. In fact, we need energy to walk, talk, and think—in short, to stay alive. The human body has trillions of cells, all hard at work, all demanding fuel continuously. In this chapter, you'll learn how cells harvest food energy and put it to work with the help of oxygen. Along the way, we'll consider the implications of how the body responds to exercise.

The science of exercise. Endurance athletes must carefully monitor their efforts so that they maintain an aerobic pace over the long term.

Energy Flow and Chemical Cycling in the Biosphere

All life requires energy. In almost all ecosystems on Earth, this energy originates with the sun. During **photosynthesis**, the energy of sunlight is converted to the chemical energy of sugars and other organic molecules (as we'll discuss in Chapter 7). Photosynthesis takes place in the chloroplasts of plants and algae, as well as in some prokaryotes. All animals depend on this conversion for food and more. You're probably wearing clothing made of a product of photosynthesis—cotton. Most of our homes are framed with lumber, which is wood produced by photosynthetic trees. Even textbooks are printed on a material (paper) that can be traced to photosynthesis in plants. But from an animal's point of view, photosynthesis is primarily about providing food.

✓ CHECKPOINT

What chemical ingredients do plants require from the environment to synthesize their own food?

Answer: CO_2 , H_2O , and soil minerals

ones. Therefore, we must eat organic material to get our nutrients and provide energy for life's processes.

Most ecosystems depend entirely on photosynthesis for food. For this reason, biologists refer to plants and other autotrophs as **producers**. Heterotrophs, in contrast, are **consumers** because they obtain their food by eating plants or by eating animals that have eaten plants (**Figure 6.1**). We animals and other heterotrophs depend on autotrophs for organic fuel and for the raw organic materials we need to build our cells and tissues. ✓

Chemical Cycling between Photosynthesis and Cellular Respiration

Within a plant, the chemical ingredients for photosynthesis are carbon dioxide (CO_2), a gas that passes from the air into a plant through tiny pores, and water (H_2O), absorbed from the soil by the plant's roots. Inside leaf cells, organelles called chloroplasts use light energy to rearrange the atoms of these ingredients to produce sugars—most importantly glucose ($\text{C}_6\text{H}_{12}\text{O}_6$)—and other organic molecules (**Figure 6.2**). You can think of chloroplasts as tiny solar-powered sugar factories. A by-product of photosynthesis is oxygen gas (O_2) that is released through pores into the atmosphere.

Producers and Consumers

Plants and other **autotrophs** (“self-feeders”) are organisms that make all their own organic matter—including carbohydrates, lipids, proteins, and nucleic acids—from nutrients that are entirely inorganic: carbon dioxide from the air and water and minerals from the soil. In other words, autotrophs make their own food; they don't need to eat to gain energy to power their cellular processes. In contrast, humans and other animals are **heterotrophs** (“other-feeders”), organisms that cannot make organic molecules from inorganic

► **Figure 6.1 Producer and consumer.** A koala (consumer) eating leaves produced by a photosynthetic plant (producer).



A chemical process called cellular respiration uses O_2 to convert the energy stored in the chemical bonds of sugars to another source of chemical energy called ATP. Cells expend ATP for almost all their work. In both plants and animals, the production of ATP during cellular respiration occurs mainly in the organelles called mitochondria (see Figure 4.19).

You might notice in Figure 6.2 that energy takes a one-way trip through an ecosystem, entering as sunlight and exiting as heat. Chemicals, in contrast, are recycled. Notice also in Figure 6.2 that the waste products of cellular respiration are CO_2 and H_2O —the very same ingredients used as inputs for photosynthesis. Plants store chemical energy through photosynthesis and then harvest this energy through cellular respiration. (Note that plants perform *both* photosynthesis to produce fuel molecules

and cellular respiration to burn them, while animals perform *only* cellular respiration.) Plants usually make more organic molecules than they need for fuel. This photosynthetic surplus provides material for the plant to grow or can be stored (as starch in potatoes, for example). Thus, when you consume a carrot, potato, or turnip, you are eating the energy reservoir that plants (if unharvested) would have used to grow the following spring.

People have always taken advantage of plants' photosynthetic abilities by eating them. More recently, engineers have managed to tap into this energy reserve to produce liquid biofuels, primarily ethanol (see Chapter 7 for a discussion of biofuels). But no matter the end product, you can trace the energy and raw materials for growth back to solar-powered photosynthesis. ✓

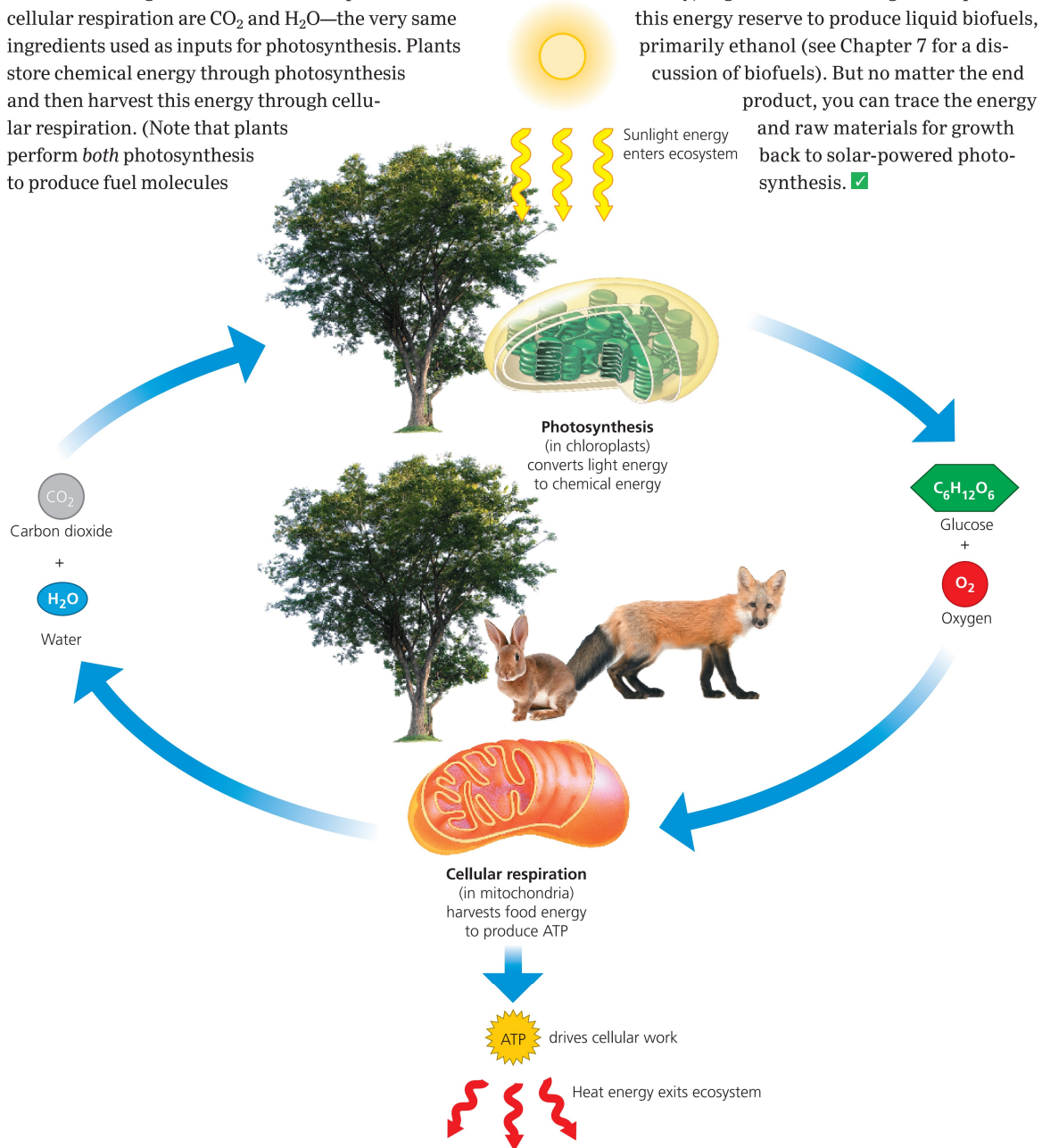

✓ CHECKPOINT

What is misleading about the following statement? "Plants perform photosynthesis, whereas animals perform cellular respiration."

Answer: It implies that only animals perform cellular respiration, when in fact all life does.

◀ **Figure 6.2** Energy flow and chemical cycling in ecosystems. Energy flows through an ecosystem, entering as sunlight and exiting as heat. In contrast, chemical elements are recycled within an ecosystem.



Mastering Biology
goo.gl/SvLydh

Cellular Respiration: Aerobic Harvest of Food Energy

We usually use the word *respiration* to mean breathing. Although respiration on the organismal level should not be confused with cellular respiration, the two processes are closely related (Figure 6.3). Cellular respiration requires

a cell to exchange two gases with its surroundings. The cell takes in oxygen in the form of the gas O_2 . It gets rid of waste in the form of the gas carbon dioxide, or CO_2 . Respiration, or breathing, results in the exchange of these same gases

✓ CHECKPOINT

At both the organismal and cellular levels, respiration involves taking in the gas _____ and expelling the gas _____.

Answer: O_2 ; CO_2 ■

▼ Figure 6.3 How breathing is related to cellular respiration.

When you inhale, you breathe in O_2 . The O_2 is delivered to your cells, where it is used in cellular respiration. Carbon dioxide, a waste product of cellular respiration, diffuses from your cells to your blood and travels to your lungs, where it is exhaled.

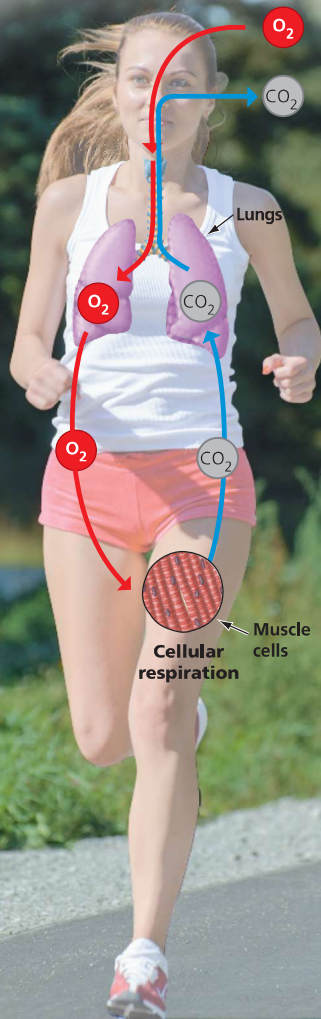

YOU HAVE SOMETHING IN COMMON WITH A SPORTS CAR: YOU BOTH REQUIRE AN AIR INTAKE SYSTEM TO BURN FUEL EFFICIENTLY.

between your blood and the outside air. Oxygen present in the air you inhale diffuses across the lining of your lungs and into your bloodstream. And the CO_2 in your bloodstream diffuses into your lungs and exits your body when you exhale. Every molecule of CO_2 that you exhale was originally formed in one of the mitochondria of your body's cells. Internal combustion engines, like the ones found in cars, use O_2 (through the air intakes) to break down gasoline. A cell also requires O_2 to break down its fuel (see Figure 5.2). Cellular respiration—a biological version of internal combustion—is the main way

that chemical energy is harvested from food and converted to ATP energy (see Figure 5.6). Cellular respiration is an **aerobic** process, which is just another way of saying that it requires oxygen. Putting all this together, we can now define **cellular respiration** as the aerobic harvesting of chemical energy from organic fuel molecules. ✓

An Overview of Cellular Respiration

All living organisms depend on transformations of energy and matter. We see examples of such transformations throughout the study of life, but few are as important as the conversion of energy in fuel (food molecules) to a form that cells can use directly. Most often, the fuel molecule used by cells is glucose, a simple sugar (monosaccharide) with the formula $C_6H_{12}O_6$ (see Figure 3.6). (Less often, other organic molecules are used to gain energy.) This equation summarizes the transformation of glucose during cellular respiration:



The series of arrows in this formula represents the fact that cellular respiration consists of many chemical steps. A specific enzyme catalyzes each reaction in the pathway, more than two dozen reactions in all. In fact, these reactions constitute one of the most important metabolic pathways for nearly every eukaryotic cell: those found in plants, fungi, protists, and animals. This pathway provides the energy these cells need to maintain the functions of life.

The many chemical reactions that make up cellular respiration can be grouped into three main stages: glycolysis, the citric acid cycle, and electron transport. **Figure 6.4** is a road map that will help you follow the three stages of respiration and see where each stage occurs in your cells. During **glycolysis**, a molecule of glucose is split into two molecules of a compound called pyruvic acid. The enzymes for glycolysis are located in the cytoplasm. The **citric acid cycle** (also called the Krebs cycle) completes the breakdown of glucose all the way to CO_2 , which is then released as a waste product. The enzymes for the citric acid cycle are dissolved in the fluid within mitochondria. Glycolysis and the citric acid cycle generate a small amount of ATP directly. They generate much more ATP indirectly, by reactions that transfer electrons from fuel molecules to a molecule called NAD^+ (nicotinamide adenine dinucleotide) that cells make from niacin, a B vitamin. The electron transfer forms a molecule called **NADH** (the H represents the transfer of

hydrogen along with the electrons) that acts as a shuttle carrying high-energy electrons from one area of the cell to another. The third stage of cellular respiration is **electron transport**. Electrons captured from food by the NADH formed in the first two stages are stripped of their energy, a little bit at a time, until they are finally combined with oxygen to form water. The proteins and other molecules that make up electron transport chains are embedded within the inner membrane of the mitochondria. The transport of electrons from NADH to oxygen releases the energy your cells use to make most of their ATP.

The overall equation for cellular respiration shows that the atoms of the reactant molecules glucose and oxygen are rearranged to form the products carbon dioxide and water. But don't lose track of why this process occurs: The main function of cellular respiration is to generate ATP for cellular work. In fact, the process can produce around 32 ATP molecules for each glucose molecule consumed. ✓

✓ **CHECKPOINT**

Which stages of cellular respiration take place in the mitochondria? Which stage takes place outside the mitochondria?

Answer: the citric acid cycle and electron transport; glycolysis

► **Figure 6.4** A road map for cellular respiration.

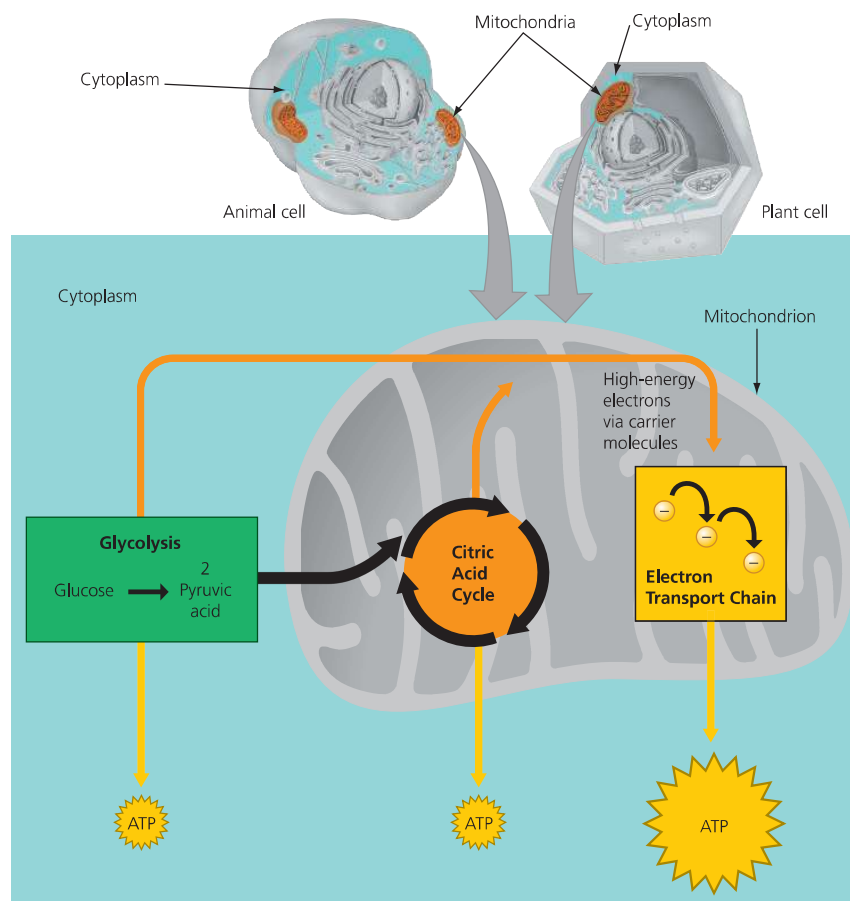

The Three Stages of Cellular Respiration

Now that you have a big-picture view of cellular respiration, let's examine the process in more detail. A small version of Figure 6.4 will help you keep the overall process of cellular respiration in plain view as we take a closer look at its three stages.

Stage 1: Glycolysis

The word *glycolysis* means “splitting of sugar” (Figure 6.5), and that's just what happens. **1** During glycolysis, a six-carbon glucose molecule is broken in

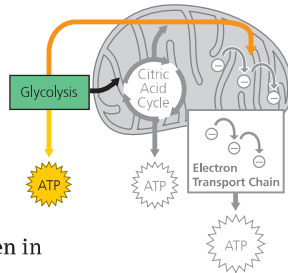

half, forming two three-carbon molecules. Notice in Figure 6.5 that the initial split requires an energy “investment” of two ATP molecules per glucose. **2** The three-carbon molecules then donate high-energy electrons to NAD^+ , forming NADH. **3** In addition to NADH, glycolysis also “banks” four ATP groups directly when enzymes transfer phosphate groups from fuel molecules to ADP. Glycolysis thus produces a “profit” of two molecules of ATP per molecule of glucose (two invested, but four banked; this fact will become important during our discussion of fermentation later). What remains of the fractured glucose at the end of glycolysis are two molecules of pyruvic acid. The pyruvic acid still holds most of the energy of glucose, and that energy is harvested in the second stage of cellular respiration, the citric acid cycle.

▼ **Figure 6.5 Glycolysis.** In glycolysis, a team of enzymes splits glucose, eventually forming two molecules of pyruvic acid. After investing 2 ATP at the start, glycolysis generates 4 ATP directly. More energy will be harvested later from high-energy electrons used to form NADH and from the two molecules of pyruvic acid.

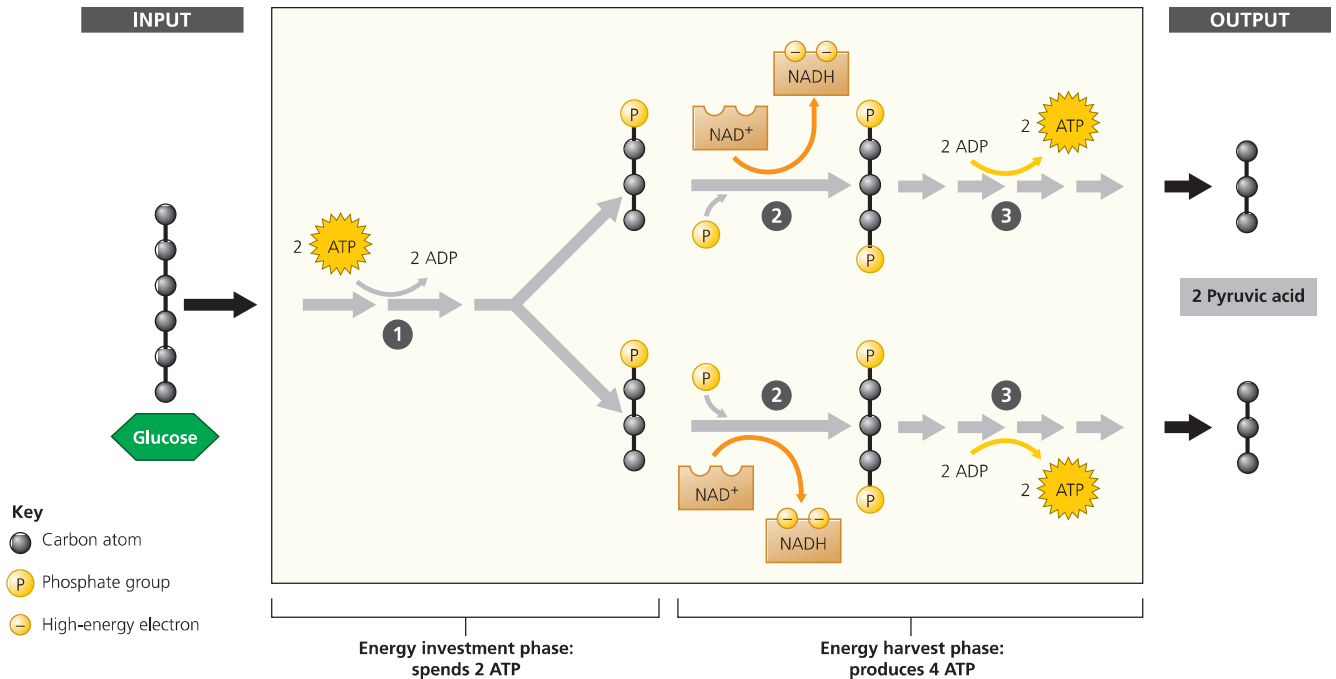

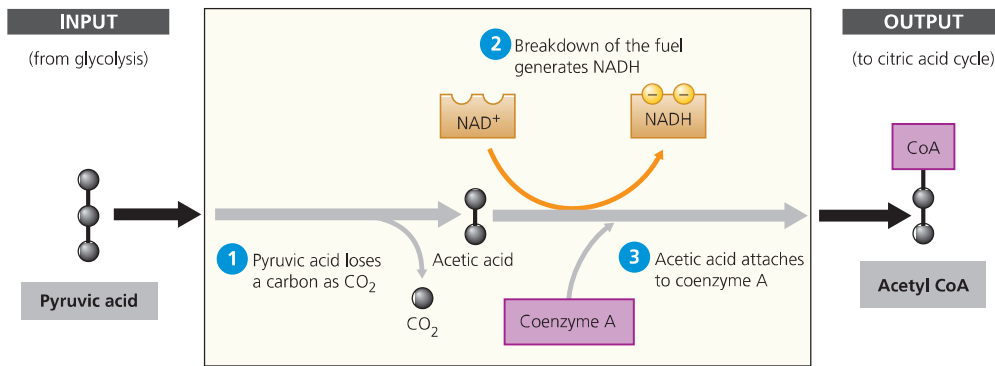

◀ **Figure 6.6** The link between glycolysis and the citric acid cycle: the conversion of pyruvic acid to acetyl CoA. Remember that one molecule of glucose is split into two molecules of pyruvic acid. Therefore, the process shown here occurs twice for each starting glucose molecule.

Stage 2: The Citric Acid Cycle

During glycolysis, one molecule of glucose is split into two molecules of pyruvic acid. But before pyruvic acid can be used by the citric acid cycle, it must be “groomed”—converted to a form the citric acid cycle can use (**Figure 6.6**). **1** First, each pyruvic acid loses a carbon as CO_2 . This is the first of this waste product we’ve seen so far in the breakdown of glucose. The remaining fuel molecules, each with only two carbons left, are called acetic acid (the acid that’s in vinegar). **2** Electrons are stripped from these molecules and transferred to another molecule of NAD^+ , forming more NADH. **3** Finally, each acetic acid is attached to a molecule called coenzyme A (CoA), an enzyme derived from the B vitamin pantothenic acid, to form acetyl CoA. The

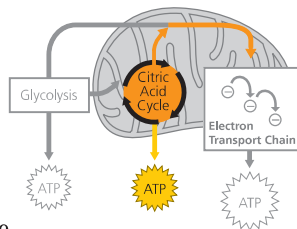

CoA escorts the acetic acid into the first reaction of the citric acid cycle. The CoA is then stripped and recycled.

The citric acid cycle finishes extracting the energy of sugar by dismantling the acetic acid molecules all the way down to CO_2 (**Figure 6.7**). **1** Acetic acid joins a four-carbon acceptor molecule to form a six-carbon product called citric acid (for which the cycle is named). For every acetic acid molecule that enters the cycle as fuel, **2** two CO_2 molecules eventually exit as a waste product. Along the way, the citric acid cycle harvests energy from the fuel. **3** Some of the energy is used to produce ATP directly. However, the cycle captures much more energy in the form of **4** NADH and **5** a second, closely related electron carrier called FADH_2 . **6** All the carbon atoms that entered the cycle as fuel are accounted for as CO_2 exhaust, and the four-carbon acceptor molecule is recycled. We have tracked only one acetic acid molecule through the citric acid cycle here. But because glycolysis splits glucose in two, the citric acid cycle occurs twice for each glucose molecule that fuels a cell. ✓

✓ CHECKPOINT

- Two molecules of what compound are produced by glycolysis? Does this molecule enter the citric acid cycle?
- Pyruvic acid must travel from the _____, where glycolysis takes place, to the _____, where the citric acid cycle takes place.

Answers: **1** Pyruvic acid. No; it is first converted to acetic acid. **2** cytoplasm; mitochondria

▶ **Figure 6.7**
The citric acid cycle.

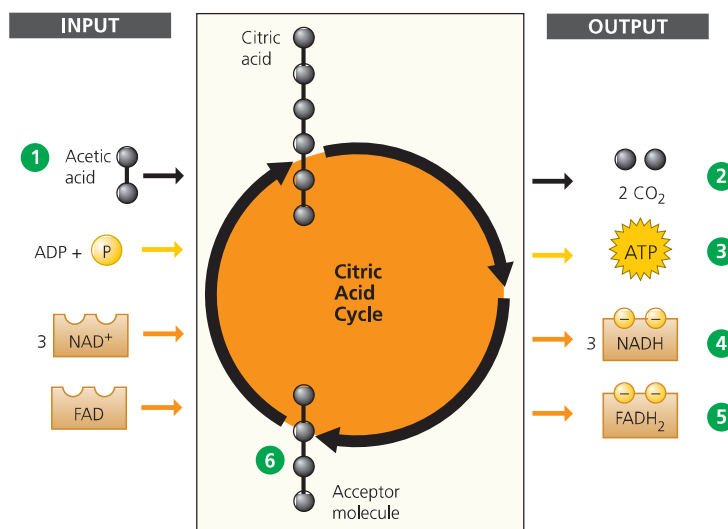

Stage 3: Electron Transport

During cellular respiration, the electrons gathered from food molecules gradually “fall,” losing energy at each step. In this way, cellular respiration unlocks chemical energy in small amounts, bit by bit, that cells can put to productive use.

Electrons are transferred from glucose in food molecules to NAD^+ . This electron transfer converts NAD^+ to NADH . Then NADH releases two electrons that enter an **electron transport chain**, a series of electron carrier molecules. This chain is like a bucket brigade, with each molecule passing an electron to the next molecule. With each exchange, the electron gives up a bit of energy. This downward cascade releases energy from the electron and uses it to make ATP (**Figure 6.8**).

Let’s take a closer look at the path that electrons take (**Figure 6.9**). Each link in an electron transport chain is a molecule, usually a protein (shown as purple circles in Figure 6.9). In a series of reactions, each member of the chain transfers electrons. With each transfer, the electrons give up a small amount of energy that can then be used indirectly to generate ATP. The first molecule of the chain accepts electrons from NADH . Thus, NADH carries electrons from glucose and other fuel molecules and deposits them at the

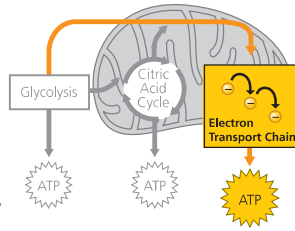

top of an electron transport chain. The molecule at the bottom of the chain finally “drops” the electrons to oxygen. At the same time, oxygen picks up hydrogen, forming water.

The overall effect of all this transfer of electrons during cellular respiration is a “downward” trip for electrons from glucose to NADH to an electron transport chain to oxygen. During the stepwise release of chemical energy in the electron transport chain, our cells make most of their ATP. It is actually oxygen, the “electron grabber,” at the end, that makes it all possible. By pulling electrons down the transport chain from fuel molecules, oxygen functions somewhat like gravity pulling objects downhill. Because oxygen is the final electron acceptor, we cannot survive more than a few minutes without breathing. Viewed this way, drowning is deadly because it deprives cells of the final “electron grabbers” (oxygen) needed to drive cellular respiration.



► **Figure 6.8** Cellular respiration illustrated using a hard-hat analogy. Splitting the bonds of a molecule of glucose provides the energy that boosts an electron from a low-energy state to a high-energy state.

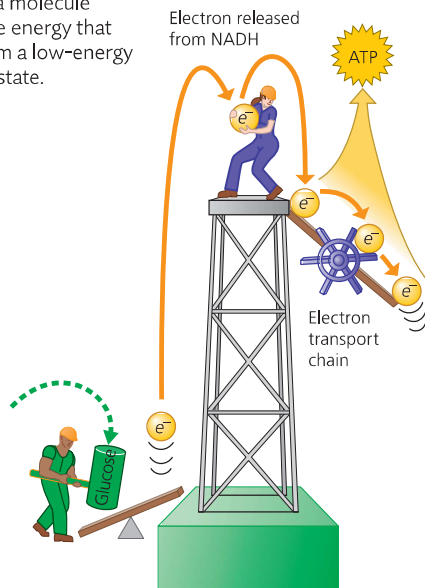

▼ **Figure 6.9** The role of oxygen in harvesting food energy. In cellular respiration, electrons “fall” in small steps from food to oxygen, producing water. NADH transfers electrons from food to an electron transport chain. The attraction of oxygen to electrons “pulls” the electrons down the chain.

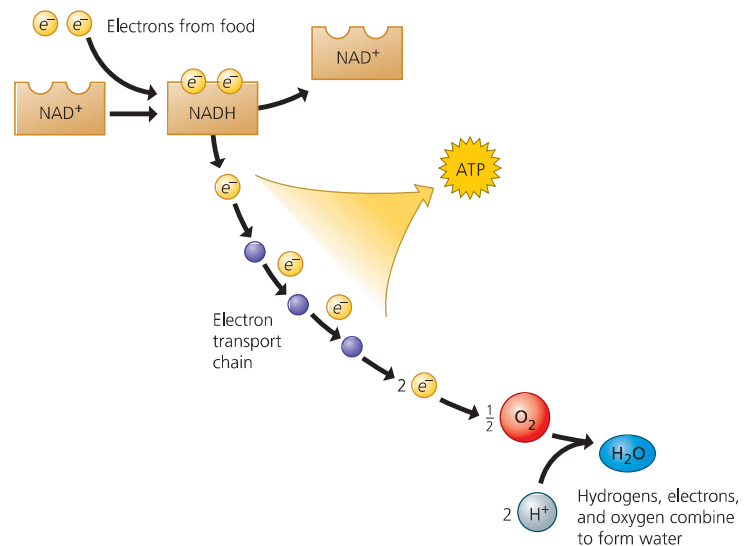

The molecules of electron transport chains are built into the inner membranes of mitochondria (see Figure 4.19). **Because these membranes are highly folded, their large surface area can accommodate thousands of copies of the electron transport chain—a good example of how biological structure fits function.** Each chain acts as a chemical pump that uses the energy released by the “fall” of electrons to move hydrogen ions (H^+) across the inner mitochondrial membrane. This pumping causes ions to become more concentrated



concentrated on one side of the membrane than on the other. Such a difference in concentration stores potential energy, similar to the way water can be stored behind a dam. There is a tendency for hydrogen ions to gush back to where they are less concentrated, just as

there is a tendency for water to flow downhill. The inner membrane temporarily “dams” hydrogen ions.

The energy of dammed water can be harnessed to perform work. Gates in a dam allow the water to rush

downhill, turning giant turbines, and this work can be used to generate electricity. Your mitochondria have structures that act like turbines. Each of these miniature machines, called an **ATP synthase**, is constructed from proteins built into the inner mitochondrial membrane, adjacent to the proteins of the electron transport chains.

Figure 6.10 shows a simplified view of how the energy previously stored in NADH and $FADH_2$ can now be used to generate ATP. **1** NADH and **2** $FADH_2$ transfer electrons to an electron transport chain. **3** The electron transport chain uses this energy supply to pump H^+ across the inner mitochondrial membrane. **4** Oxygen pulls electrons down the transport chain. **5** The H^+ concentrated on one side of the membrane rushes back “downhill” through an ATP synthase. This action spins a component of the ATP synthase, just as water turns the turbines in a dam. **6** The rotation activates parts of the synthase molecule that attach phosphate groups to ADP molecules to generate ATP.

The poison cyanide produces its deadly effect by binding to one of the protein complexes in the electron transport chain (marked with a skull-and-crossbones symbol in Figure 6.10). When bound there, cyanide blocks the passage of electrons to oxygen. This blockage is like clogging the outflow channel of a dam. As a result, no H^+ gradient is generated, and no ATP is made. Cells stop working, and the organism dies. **✓**

✓ CHECKPOINT

What is the potential energy source that drives ATP production by ATP synthase?

Answer: a concentration gradient of H^+ across the inner membrane of a mitochondrion

▼ Figure 6.10 How electron transport drives ATP synthase machines.

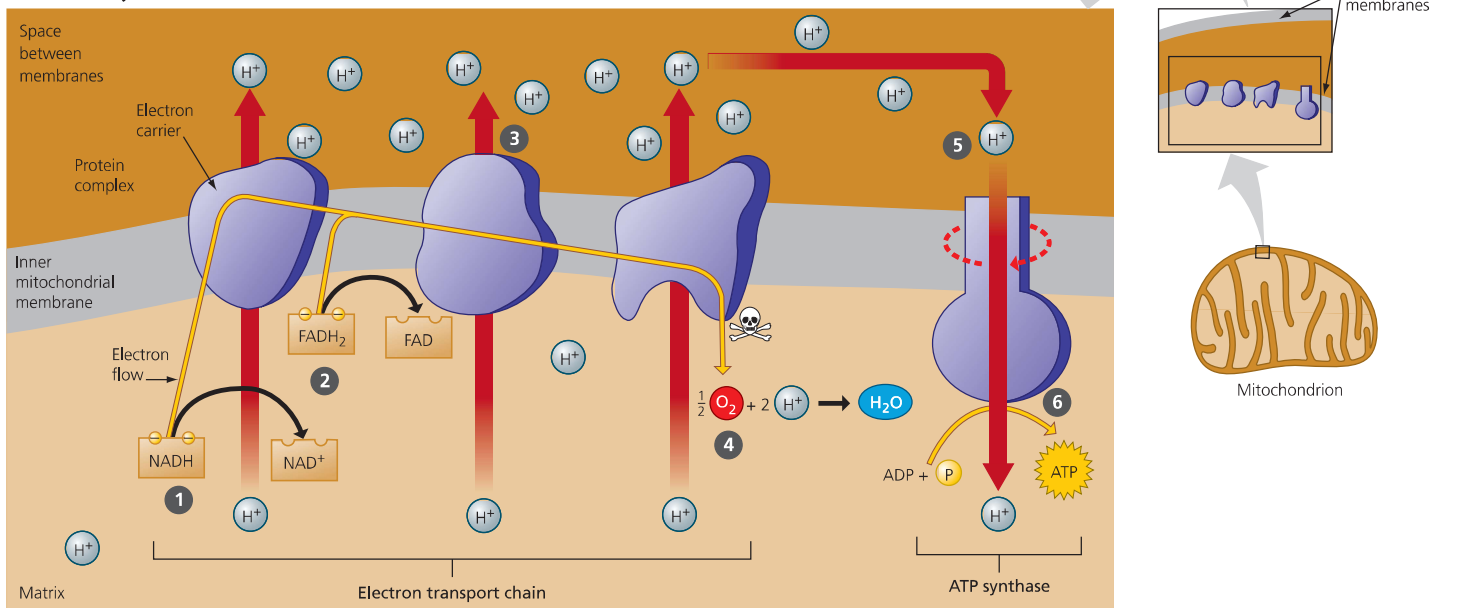

The Results of Cellular Respiration

When taking cellular respiration apart to see how all the molecular nuts and bolts of its metabolic machinery work, it's easy to lose sight of its overall function: to generate about 32 molecules of ATP per molecule of glucose (the actual number can vary by a few, depending on the organism and molecules involved). **Figure 6.11** will help you keep track of the ATP molecules generated. As we discussed, glycolysis and the citric acid cycle each contribute 2 ATP by directly making it. The rest of the ATP molecules are produced by ATP synthase, powered by the “fall” of electrons from food to oxygen. The electrons are carried from the organic fuel to electron transport chains by NADH and FADH_2 . Each electron pair “dropped” down a transport chain from NADH or FADH_2 can power the synthesis of a few ATP. You can visualize the process like this: Energy flows from glucose to carrier molecules and ultimately to ATP.

We have seen that glucose can provide the energy to make the ATP our cells use for all their work. All of the energy-consuming activities of your body—moving your muscles, maintaining your heart-beat and temperature, and even the thinking that goes on within your brain—can be traced back to ATP and, before that, the glucose that was used to make it. The importance of glucose is underscored by the severity of diseases in which glucose balance is disturbed. Diabetes, which affects more than 20 million Americans, is caused by an inability to properly regulate glucose levels in the blood due to problems with the hormone insulin. If left untreated, a glucose imbalance can lead to a variety of problems, including cardiovascular disease, coma, and even death.

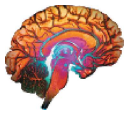

THE CELLS OF YOUR BRAIN BURN THROUGH A QUARTER POUND OF GLUCOSE EACH DAY.

✓ CHECKPOINT

Which stage of cellular respiration produces the majority of ATP?

Answer: electron transport

► **Figure 6.11** A summary of ATP yield during cellular respiration.

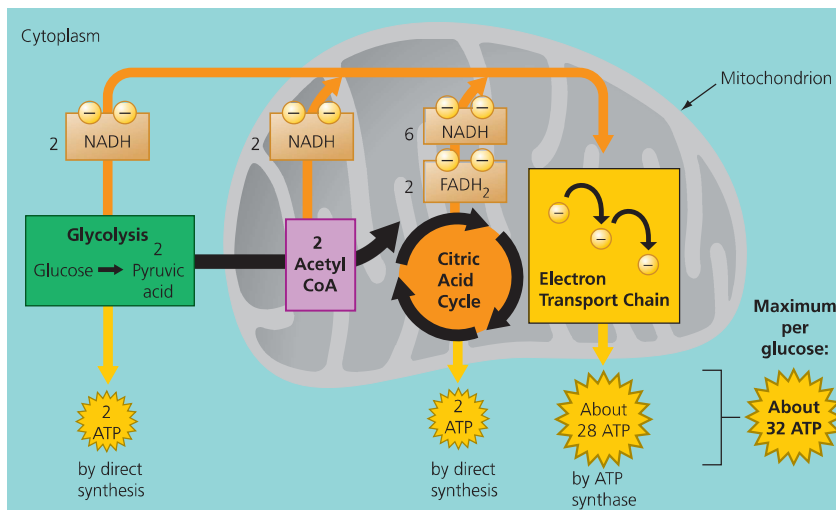

▼ **Figure 6.12** Energy from food. The monomers from carbohydrates (polysaccharides and sugars), fats, and proteins can all serve as fuel for cellular respiration.

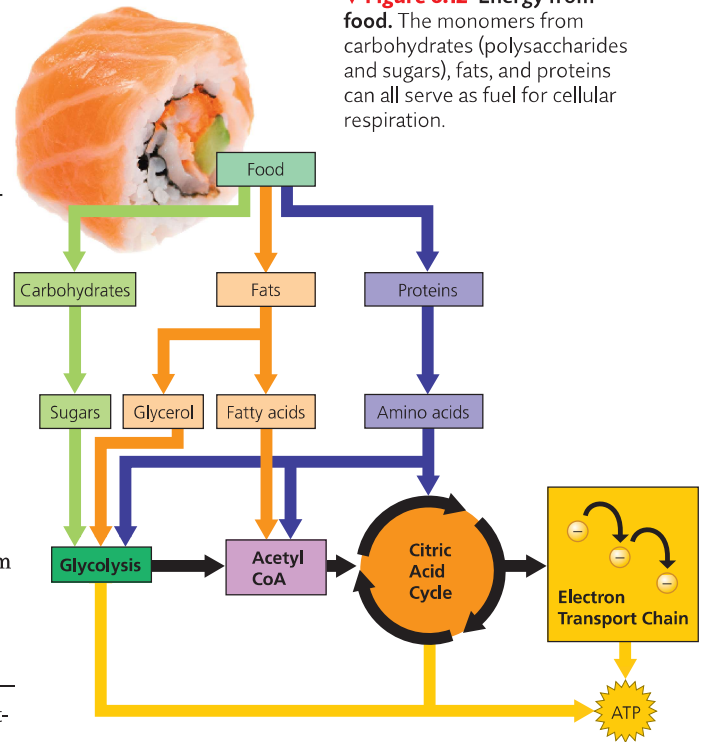

But even though we have concentrated on glucose as the fuel that is broken down during cellular respiration, respiration is a versatile metabolic furnace that can “burn” many other kinds of food molecules. **Figure 6.12** diagrams some metabolic routes for the use of carbohydrates, fats, and proteins as fuel for cellular respiration. Taken together, all of these food molecules make up your calorie-burning metabolism. **The interplay between these pathways provides a clear example of the theme of system interactions; in this case, all of these interactions contribute to maintaining a balanced metabolism.** ✓

Fermentation: Anaerobic Harvest of Food Energy

Although you must breathe to stay alive, some of your cells can work for short periods without oxygen. This **anaerobic** (“without oxygen”) harvest of food energy is called fermentation.

Fermentation in Human Muscle Cells

You know by now that as your muscles work, they require a constant supply of ATP, which is generated by cellular respiration. As long as your blood provides your muscle cells with enough O_2 to keep electrons “falling” down transport chains in mitochondria, your muscles will work aerobically.

But under strenuous conditions, your muscles can spend ATP faster than your bloodstream can deliver O_2 ; when this happens, your muscle cells begin to work anaerobically. After functioning anaerobically for about 15 seconds, muscle cells will begin to generate ATP by the process of fermentation. **Fermentation** relies on glycolysis, the first stage of cellular respiration. Glycolysis does not require O_2 but does produce two ATP molecules for each glucose molecule broken down to pyruvic acid. That isn’t very efficient

compared with the 32 or so ATP molecules each glucose molecule generates during cellular respiration, but it can energize muscles for a short burst of activity. However, in such situations your cells will have to consume more glucose fuel per second because so much less ATP per glucose molecule is generated under anaerobic conditions. **Fermentation in muscle cells may be a vestige of evolution (see the Evolution Connection section) and provides a survival advantage even today.**

To harvest food energy during glycolysis, NAD^+ must be present to receive electrons (see Figure 6.9). This is no problem under aerobic conditions because the cell regenerates NAD^+ when NADH drops its electron cargo down electron transport chains to O_2 . However, this recycling of NAD^+ cannot occur under anaerobic conditions because there is no O_2 to accept the electrons. Instead, NADH disposes of electrons by adding them to the pyruvic acid produced by glycolysis (**Figure 6.13**). This restores NAD^+ and keeps glycolysis working.

The addition of electrons to pyruvic acid produces a waste product called lactic acid. The lactic acid by-product is eventually transported to the liver, where liver cells convert it back to pyruvic acid. Exercise scientists have long speculated about the role that lactic acid plays in muscle fatigue, as you’ll see next. ✓

✓ CHECKPOINT

How many molecules of ATP can be produced from one molecule of glucose during fermentation?

Answer: two



▼ Figure 6.13 Fermentation: producing lactic acid.

Glycolysis produces ATP even in the absence of O_2 . This process requires a continuous supply of NAD^+ to accept electrons from glucose. The NAD^+ is regenerated when NADH transfers the electrons it removed from food to pyruvic acid, thereby producing lactic acid (or other waste products, depending on the species of organism).

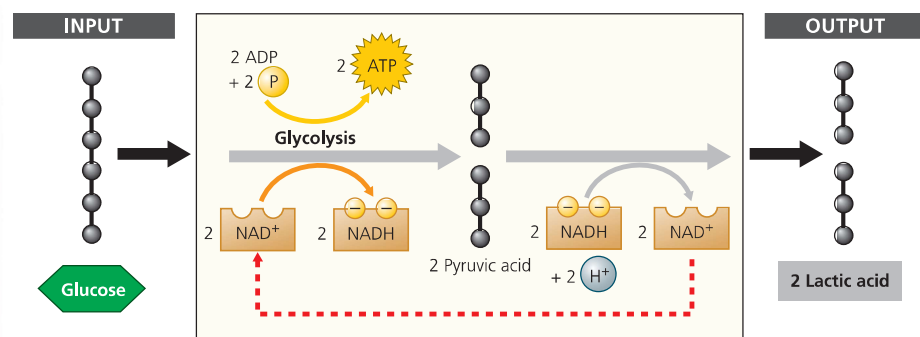

THE PROCESS OF SCIENCE Exercise Science

What Causes Muscle Burn?

BACKGROUND

You probably know that your muscles burn after hard exercise (“Feel the burn!”). But what causes the burn? This question was investigated by one of the founders of the field of exercise science, a British biologist named A.V. Hill. In fact, Hill won a 1922 Nobel Prize for his investigations of muscle contraction.

Hill knew that muscles produce lactic acid under anaerobic conditions. In 1929, Hill developed a technique for electrically stimulating dissected frog muscles in a laboratory solution. He wondered if a buildup of lactic acid would cause muscle activity to stop.

METHOD

Hill’s experiment tested frog muscles under two different sets of conditions (Figure 6.14). First, he showed that muscle performance declined when lactic acid could not diffuse away from the muscle tissue. Next, he showed that when lactic acid was allowed to diffuse away, performance improved significantly. These results led Hill to the conclusion that the buildup of lactic acid is the primary cause of muscle failure under anaerobic conditions.

RESULTS

Given his scientific stature—he was considered the world’s leading authority on muscle activity—Hill’s conclusion went unchallenged for many decades. Gradually, however, evidence that contradicted Hill’s results began to accumulate. For example, the effect that Hill demonstrated did not appear to occur at human body temperature. And certain people who are unable to accumulate lactic acid have muscles that

fatigue *more* rapidly, which is the opposite of what you would expect. Recent experiments have directly refuted Hill’s conclusions. Some research indicates that increased levels of other ions may be to blame. Therefore, the cause of muscle fatigue remains hotly debated.

The changing view of lactic acid’s role in muscle fatigue illustrates an important point about the process of science: Scientific belief is dynamic and subject to constant adjustment as new evidence is uncovered. This would not have surprised Hill, who himself observed that all scientific hypotheses may become obsolete, and that changing conclusions in light of new evidence is necessary for the advancement of science.

▼ Figure 6.14 A. V. Hill’s 1929 apparatus for measuring muscle fatigue.

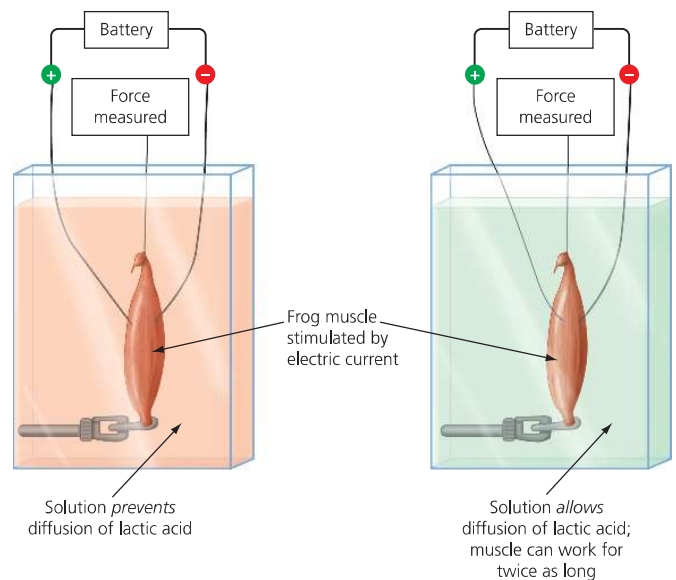

Thinking Like a Scientist

The explanation for the cause of muscle burn has changed over time as new evidence has accumulated. Does this represent a failure of the scientific method?

For the answer, see Appendix D.

Fermentation in Microorganisms

Our muscles cannot rely on lactic acid fermentation for very long. However, the two ATP molecules produced per glucose molecule during fermentation are enough to sustain

many microorganisms. We have domesticated such microbes to transform milk into cheese, sour cream, and yogurt. These foods owe their

sharp or sour flavor mainly to lactic acid. The food industry also uses fermentation to produce soy sauce from soybeans, to pickle cucumbers, olives, and cabbage, and to produce meat products like sausage, pepperoni, and salami.

Yeast, a microscopic fungus, is capable of both cellular respiration and fermentation. When kept in an anaerobic environment, yeast cells ferment sugars and other foods to stay alive. As they do, the yeast produce ethyl alcohol as a waste product instead of lactic acid



THE METABOLIC PROCESSES THAT PRODUCE ACID IN YOUR MUSCLES AFTER A HARD WORKOUT ARE SIMILAR TO THE PROCESSES THAT PRODUCE PEPPERONI, SOY SAUCE, YOGURT, AND BREAD.

(Figure 6.15). This alcoholic fermentation also releases CO_2 . For thousands of years, people have put yeast to work producing alcoholic beverages such as beer and wine using airtight barrels and vats, where the lack of oxygen forces

the yeast to ferment glucose into ethanol. And as every baker knows, the CO_2 bubbles from fermenting yeast also cause bread dough to rise. (The alcohol produced in fermenting bread is burned off during baking.)

▼ **Figure 6.15 Fermentation: producing ethyl alcohol.** The alcohol produced by yeast as bread rises is burned off during baking.

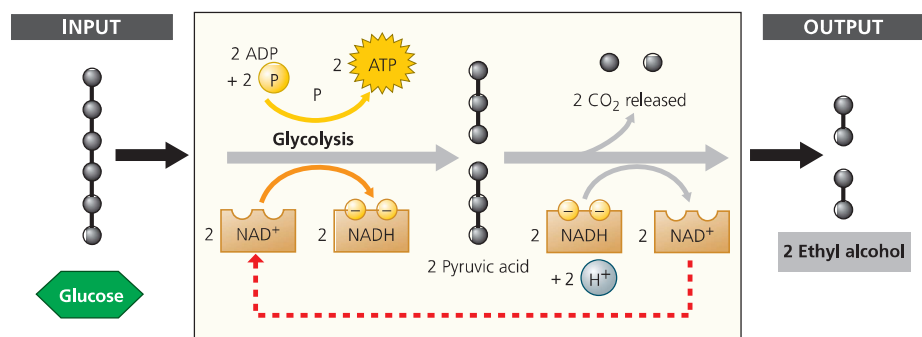

✓ **CHECKPOINT**

What kind of acid builds up in human muscle during strenuous activity?

Answer: lactic acid

EVOLUTION CONNECTION Exercise Science

The Importance of Oxygen

In the Biology and Society and the Process of Science sections, we were reminded of the important role that oxygen plays during aerobic exercise. But in the last section on fermentation, we learned that exercise can continue on a limited basis even under anaerobic (oxygen-free) conditions. Both aerobic and anaerobic respiration start with glycolysis, the splitting of glucose to form pyruvic acid. Glycolysis is thus the universal energy-harvesting process of life. If you looked inside a bacterial cell, one of your body cells, or any other living cell, you would find the metabolic machinery of glycolysis.

The universality of glycolysis in life on Earth has an evolutionary basis. Ancient prokaryotes probably used glycolysis to make ATP long before oxygen was present in Earth's atmosphere. The oldest known fossils of bacteria date back more than 3.5 billion years and resemble some living photosynthetic bacteria. Evidence indicates, however, that significant levels of O_2 , formed as a by-product of bacterial photosynthesis, did not accumulate in the atmosphere until about 2.7 billion years ago (Figure 6.16). For almost 1 billion years, prokaryotes must have generated ATP exclusively from glycolysis, a process that does not require oxygen.

The fact that glycolysis occurs in almost all organisms suggests that it evolved very early in ancestors common to all the domains of life. The location of glycolysis within the cell also implies great antiquity; the

pathway does not require any of the membrane-enclosed organelles of the eukaryotic cell, which evolved about a billion years after the prokaryotic cell. Glycolysis is a metabolic heirloom from early cells that continues to function in fermentation and as the first stage in the breakdown of organic molecules by cellular respiration. The ability of our muscles to function anaerobically can therefore be viewed as a vestige of our ancient ancestors, who relied exclusively on this metabolic pathway.

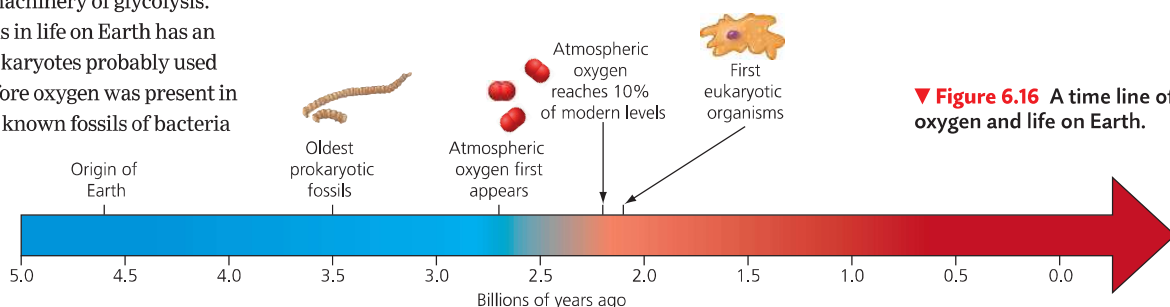

▼ **Figure 6.16** A time line of oxygen and life on Earth.



Chapter Review

SUMMARY OF KEY CONCEPTS

Energy Flow and Chemical Cycling in the Biosphere

Producers and Consumers

Autotrophs (producers) make organic molecules from inorganic nutrients by photosynthesis. Heterotrophs (consumers) must consume organic material and obtain energy by cellular respiration.

Chemical Cycling between Photosynthesis and Cellular Respiration

The molecular outputs of cellular respiration— CO_2 and H_2O —are the molecular inputs of photosynthesis, and vice versa. While these chemicals cycle through an ecosystem, energy flows through, entering as sunlight and exiting as heat.

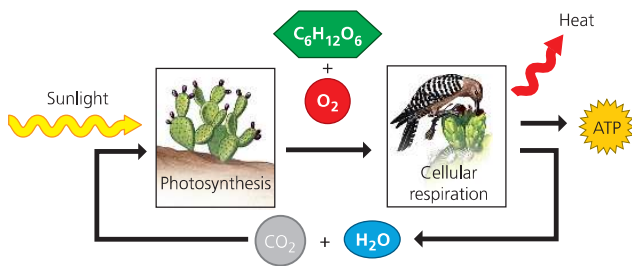

Cellular Respiration: Aerobic Harvest of Food Energy

An Overview of Cellular Respiration

The overall equation of cellular respiration simplifies a great many chemical steps into one formula:



The Three Stages of Cellular Respiration

Cellular respiration occurs in three stages. During glycolysis, a molecule of glucose is split into two molecules of pyruvic acid, producing two molecules of ATP and two high-energy electrons stored in NADH. During the citric acid cycle, what remains of glucose is completely broken down to CO_2 , producing a bit of ATP and a lot of high-energy electrons stored in NADH and FADH_2 . The electron transport chain uses the high-energy electrons to pump H^+ across the inner mitochondrial membrane, eventually handing them off to O_2 , producing H_2O . Backflow of H^+ across the membrane powers the ATP synthases, which produce ATP from ADP.

The Results of Cellular Respiration

You can follow the flow of molecules through the process of cellular respiration in the diagram. Notice that the first two stages primarily produce high-energy electrons carried by NADH and that it is the final stage that uses these high-energy electrons to produce the bulk of the ATP molecules produced during cellular respiration.

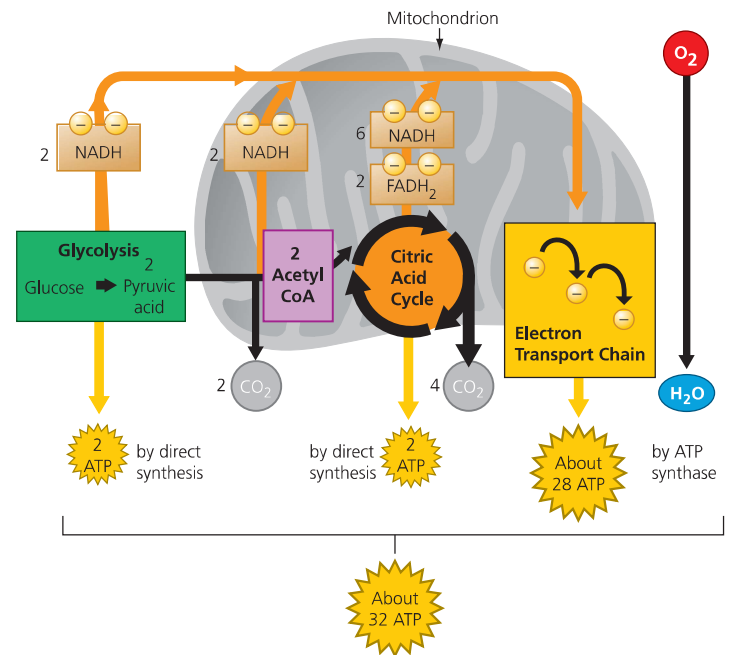

Fermentation: Anaerobic Harvest of Food Energy

Fermentation in Human Muscle Cells

When muscle cells consume ATP faster than O_2 can be supplied for cellular respiration, the conditions become anaerobic, and muscle cells will begin to regenerate ATP by fermentation. The waste product under these anaerobic conditions is lactic acid. The ATP yield per glucose is much lower during fermentation (2 ATP) than during cellular respiration (about 32 ATP).

Fermentation in Microorganisms

Yeast and some other organisms can survive with or without O_2 . Wastes from fermentation can be ethyl alcohol, lactic acid, or other compounds, depending on the species.

Mastering Biology

For practice quizzes, BioFlix animations, MP3 tutorials, video tutors, and more study tools designed for this textbook, go to Mastering Biology™