

# Problematic Internet usage, personality, loneliness, and psychological well-being in emerging adulthood

Francesca Dalton | Tony Cassidy 

School of Psychology, Ulster University,  
Coleraine, Northern Ireland

## Correspondence

Tony Cassidy, School of Psychology, Ulster  
University, Coleraine, Northern Ireland.  
Email: t.cassidy@ulster.ac.uk

## Abstract

The current study explored the relationship between problem Internet use, personality, loneliness, and well-being in emerging adulthood. An online survey using questionnaires assessed 673 emerging adults (247 males and 426 females) aged between 18 and 25 years on measures of problem Internet use, personality, loneliness and well-being. Results show that problematic Internet use is directly related to emotional stability, conscientiousness, loneliness and well-being. This relationship holds which ever direction of relationship between the personality variables and problematic Internet use is posited. It is argued that understanding the risk and protective factors for problem Internet use is particularly important at this emerging adult stage where attitudes, traits and behavior are malleable. There is a need for more longitudinal data on problem Internet use in emerging adulthood in order to prevent it leading to more serious pathology.

## KEYWORDS

loneliness, personality, problematic Internet use, psychological well-being

## INTRODUCTION

A systematic review of the evidence for Internet use, self-harm and suicide in adolescents and emerging adults concluded there is significant potential for harm through normalization,

triggering, competition, and contagion (Marchant et al., 2017). However, the same review suggests there is a lot of potential to use the Internet for crisis support, reduction of sense of social isolation, delivering interventions, and outreach (Marchant et al., 2017). While caution should be exercised in pathologizing Internet behavior, there is now a widespread literature identifying Internet addiction as a disorder and reporting interventions to treat it (Kuss & Lopez-Fernandez, 2016; Kuss et al., 2014; Muusses et al., 2014; Przepiorka et al., 2014; Shapira et al., 2003; Singh Balhara et al., 2019; Thorens et al., 2014; Volungis et al., 2019; Winkler et al., 2013).

No universal definition of cognitions and behaviors associated with problematic or addictive Internet use currently exists. For the purpose of this study and for unification, problematic Internet usage has been defined as risky, impulsive, or excessive Internet use leading to social, emotional, physical, or functional impairment. Terms related to problematic Internet usage include Internet addiction and Internet dependence or compulsive Internet use (Chou et al., 2005). Prevalence rates recorded for problematic Internet usage across nine European countries were between 14% and 55% (Laconi et al., 2018) suggesting a growing trend in problematic Internet use due to the rapid development and easy access of the Internet.

The argument that problematic Internet use may be a consequence of a social need is evidence by the link between it and loneliness such that being lonely made motivate frequent use of Internet sources (Amichai-Hamburger & Ben-Artzi, 2003; Apaolaza et al., 2013; Çevik & Yildiz, 2017; Nowland et al., 2017). Some research suggests problematic Internet use can lead to a decline in social interaction subsequently increasing feelings of loneliness and negatively affecting well-being, while other evidence suggests social media sites can lower feelings of social loneliness and improve well-being (Apaolaza et al., 2013; Nowland et al., 2017).

Levels of Internet use have also been shown to relate to dimensions of personality including conscientiousness and extraversion in a range of studies (Chang et al., 2019; Jackson et al., 2003; Kayış et al., 2016; Koronczai et al., 2019; Shi & Du, 2019; Volungis et al., 2019). Kayış et al. (2016) in a meta-analysis of 12 studies concluded that Internet addiction was directly correlated with neuroticism (or emotional instability), whereas openness to experience, extraversion, conscientiousness, and agreeableness were inversely related. These were cross sectional studies so direction of causality cannot be established. Shi and Du (2019) found neuroticism to be directly related, and agreeableness and conscientiousness to be inversely related to Internet addiction in Chinese medical students. The link between neuroticism and Internet addiction seems to be fairly consistent across studies and measures (Chang et al., 2019). Koronczai et al. (2019) found a strong link between low levels of conscientiousness and Internet addiction and neuroticism had an indirect link via depression. They suggest that conscientiousness may be a protective factor and neuroticism a risk factor for Internet addiction. This raises the thorny question of direction of causality. Most researchers assume a causal link from personality to addiction though most studies are cross sectional. One longitudinal study found extraversion and neuroticism to be related to Internet use when participants first started using it, but not later (Jackson et al., 2003). However, the authors didn't measure addiction or problematic Internet use. Assuming that some dimensions of personality have a causal effect on Internet use at later stages of life might be more justified but given the malleability and changeability of personality in emerging adulthood this is problematic (Van Dijk et al., 2020; Robins et al., 2001). Reciprocal relations of causality are likely to exist.

Although the evidence is not consistent there is an argument that problematic Internet usage is linked in one way or another to loneliness and negative impact on well-being (Apaolaza et al., 2013; Muusses et al., 2014; Nowland et al., 2017). In addition, personality, particularly conscientiousness, and emotional stability (Neuroticism) is related to problematic Internet use

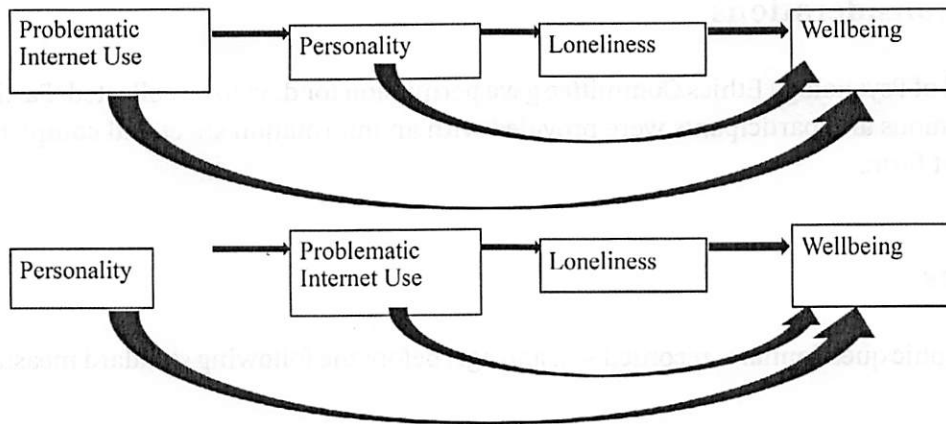

**FIGURE 1** Proposed models of the relationship between problematic Internet use and well-being

(Chang et al., 2019; Jackson et al., 2003; Kayış et al., 2016; Koronczai et al., 2019; Shi & Du, 2019; Volungis et al., 2019).

The aim of this study was to explore the relationship between problematic Internet use, the big five dimensions of personality, loneliness, and well-being in a sample of emerging adults. The evidence reviewed above is equivocal, particularly about the relationship between personality and problematic Internet use. There is evidence that personality is malleable during emerging adulthood (Blonigen et al., 2008; Branje et al., 2007). Based on the evidence two possible models of the relationship between problematic Internet usage, the big five dimensions of personality, loneliness, and well-being were proposed as shown in Figure 1. In the first model, it is proposed that problematic Internet use predicted personality, and in the second model the reverse is suggested. The aim of the study is mainly to test the relationships as proposed in both models.

## METHOD

### Participants

A sample of 673 emerging adults (247 males and 426 females) was recruited via convenience and snowball sampling to participate in this study. Participants were aged between 18 and 25 years (mean = 20.43, SD = 1.87, median and mode both = 20). A priori sample size estimation was carried out using G\*Power 3.1.9.2 for a medium effects size and a power estimation of .95 and indicated a minimum sample size of 220. With 673 participants, the study was well powered.

### Procedure

After ethical approval from the School of Psychology Ethics Committee, an online survey using the Qualtrics platform was posted on Facebook and Twitter and e-mailed to a sample of students. A participation information sheet provided details of the study and instructions for participants to follow, and a tick box consent form was completed before the questionnaire was attempted. We confirm that we have reported all measures, conditions, data exclusions, and how we determined our sample size.

## Ethical considerations

The School of Psychology Ethics Committee gave permission for data to be collected. Participation was anonymous and participants were provided with an information sheet and completed a tick box consent form.

## Measures

A demographic questionnaire recorded sex, and age, before the following standard measures were presented.

### The online cognition scale

The OCS is a 36-item questionnaire designed to measure problematic Internet use. Items on the scale focus on cognitions instead of behaviors. The OCS measures how comfortable individuals feel with their online persona versus their real-life persona, how much an individual uses the Internet to procrastinate offline responsibilities, extent to which an individual feels that the Internet is out of their control, and feelings of worthlessness related to the Internet. Responses were rated on a 7-point Likert scale of statements including "I get more respect online than in real life." Previous studies using the OCS have demonstrated reliability ranging from .81 to .94, and it has been frequently used as a reliable and valid measure of problematic Internet use (Davis et al., 2002). In the current study, the composite scale had an  $\alpha = .82$ .

### The revised UCLA loneliness scale

This is a 20-item Likert scale, measuring feelings of social isolation and loneliness. For example, "I feel in tune with the people around me" and "No one really knows me well" (Russell et al., 1980). Participants rate each item from 1 (never) to 4 (often). Jobe et al. (2007) reported high reliability, with an internal consistency of .92, and a test-retest reliability of .73. In the current study, the composite scale had an  $\alpha = .90$ .

### The 10-item personality inventory (TIPI; Gosling et al., 2003)

This is a shortened 10-item version of the Big Five Inventory designed to measure personality in terms of extraversion, agreeableness, conscientiousness, emotional stability, and openness. Gosling Rentfrow and Swann et al. (2003) report internal consistency of extraversion ( $\alpha = .87$ ), agreeableness ( $\alpha = .70$ ), conscientiousness ( $\alpha = .75$ ), neuroticism ( $\alpha = .81$ ), and openness ( $\alpha = .65$ ). Participants rate each item on a Likert scale from 1 (disagree strongly) to 7 (strongly agree). In our study, we found reliability of extraversion ( $\alpha = .85$ ), agreeableness ( $\alpha = .75$ ), conscientiousness ( $\alpha = .71$ ), emotional stability ( $\alpha = .72$ ), and openness ( $\alpha = .78$ ).

**TABLE 1** Bivariate correlations for study variables

	1	2	3	4	5	6	7
1. Well-being							
2. Loneliness	-.35::						
3. Problem Internet use	-.62::	.19::					
4. Extraversion	.18::	-.46::	-.02				
5. Agreeableness	.10::	-.47::	-.07	.10::			
6. Conscientiousness	.42::	-.19::	-.33::	.04	.21::		
7. Emotional stability	.34::	-.23::	-.21::	.23::	.18::	.25::	
8. Openness	.02	-.23::	-.01	.31::	.13::	-.02	-.22::

:p < .05.

::p < .01.

### The Warwick–Edinburgh mental well-being scale—short form

The WEMWBS-s is a seven-item measure of psychological functioning and participants subjective well-being. A Likert scale measures responses from 1 (never) to 5 (often). All items have been worded positively and address aspects of positive mental health. The WEMWBS is psychometrically robust and quick to answer. High test–retest reliability was recorded at .83. WEMWBS has good face validity among the general population with no floor or ceiling effects. Additionally, WEMWBS has good face validity among public health practitioners and policy makers in the United Kingdom (Tennant et al., 2007). The scale had an  $\alpha = .90$  in our data.

## RESULTS

The aim of this study was to test two possible models of the relationship between problematic Internet usage, personality, loneliness, and well-being as shown in Figure 1.

Before that some bivariate correlations were calculated as descriptions of the data. See Table 1.

Problematic Internet use had a highly significant inverse relationship with well-being, and a small but significant direct relationship with loneliness. It also had a significant inverse relationship with conscientiousness and emotional stability but no significant relationship with agreeableness, extraversion, or openness. Emotional stability, conscientiousness, agreeableness, and extraversion were directly correlated with well-being. Extraversion, agreeableness, conscientiousness, emotional stability, and openness, each had an inverse relationship with loneliness. The pattern of correlations fit with the proposed models.

The main aim was to test the models in Figure 1 for which we used path analysis via structural equation modeling with AMOS-25. See Figures 2 and 3.

The model in Figure 2 considered PIU as predictive of personality and was an excellent fit for the data (chi-square (2) = 6.96,  $p = .03$ , CMIN/DF = 3.48, GFI = .99, NFI = .99, IFI = .99, CFI = .99, RMSEA = .06, PCLOSE = .284).

The model in Figure 3 consider personality as predictive of PUI and was also an excellent fit for the data (chi-square (4) = 7.87,  $p = .09$ , CMIN/DF = 1.97, GFI = .99, NFI = .97, IFI = .99, CFI = .99, RMSEA = .035, PCLOSE = .639).

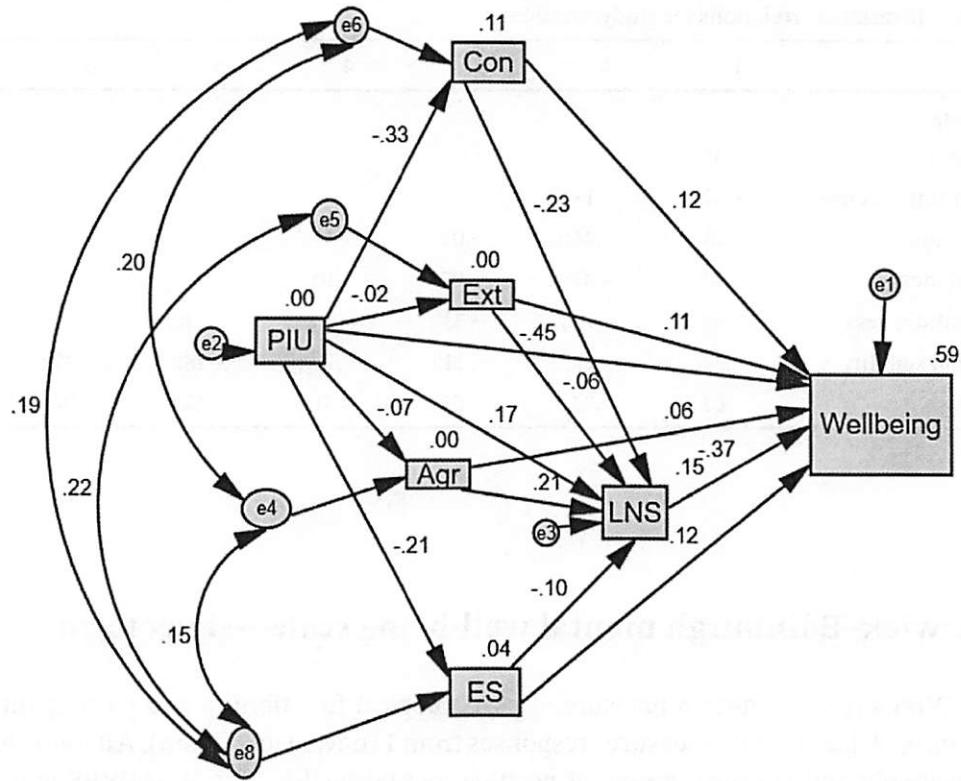

**FIGURE 2** Path model of predictors of well-being: PIU = problem Internet use; LNS = loneliness; ES = emotional stability; Con = conscientiousness; Agr = agreeableness; Ext = extraversion [Color figure can be viewed at wileyonlinelibrary.com]

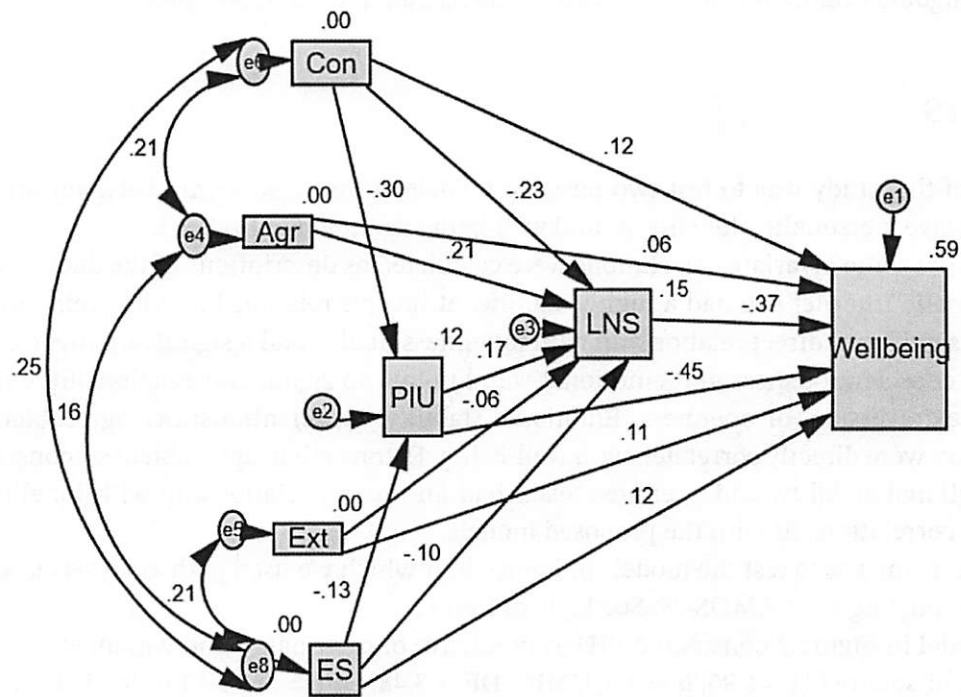

**FIGURE 3** Path model of predictors of well-being, personality preceding: PIU = problem Internet use; LNS = loneliness; Con = conscientiousness; ES = emotional stability; Agr = agreeableness; Ext = extraversion [Color figure can be viewed at wileyonlinelibrary.com]

As this is cross sectional data, it is impossible to draw definitive conclusions, but one can speculate that reciprocal relations of causality may exist. The interesting difference is that in Figure 3, neither agreeableness nor extraversion is predictive of PIU; in Figure 2, PIU is predictive of both agreeableness and extraversion.

## DISCUSSION

The aim of this study was to explore the relationship between problematic Internet use, personality, loneliness, and well-being in a sample of emerging adults, and to test if both models in Figure 1 could be supported by the data.

Results from this study indicate that problematic Internet use has a significant inverse correlation with psychological well-being. Those students who reported higher levels of problematic Internet use have lower well-being. Problematic Internet use has a significant direct correlation with loneliness. These findings are consistent with previous research by Çevik and Yildiz (2017) who found an association between increased problematic Internet use and loneliness, depression, and academic stress in International students studying abroad thus, lowering their psychological well-being. Additionally, this research is in line with Muusses et al. (2014) who provides evidence that problematic Internet use contributes to a decline in well-being over time in regard to loneliness, depression and stress. Loneliness has a significant inverse relationship with well-being as shown in previous research by Nowland et al. (2017).

Both models from Figure 1 are upheld by the data in relation to conscientiousness and emotional stability. In other words, whether conscientiousness and emotional stability are entered as predictive of problematic Internet use or as predicted by problematic Internet use the relationship is equally supported. However, with extraversion and agreeableness, the only direction that is supported by the data is where problematic Internet use is the predictor. Extraversion and agreeableness do not appear to predict problematic Internet use. Of course, this is cross-sectional data and one can only suggest that this needs to be tested in a longitudinal study. Openness to experience did not prove to have a significant relationship in the model.

The data does suggest that whatever the direction of causality, both personality and loneliness play a role in the relationship between problematic Internet use and well-being in this sample. There is some evidence that the negative impact of Internet use is more consistent in older childhood and emerging adulthood (Lobel et al., 2017; Pallavicini et al., 2018).

Research by Volungis et al. (2019) found smartphone addiction symptoms in students were positively associated with socioemotional distress including depression, anxiety, and poor interpersonal relationships stemming from loneliness. Tian et al. (2017) suggests this is due to students experiencing a shift in reliance on interpersonal relationships from family members to friends and other social relationships contributing to problematic Internet use. Additionally, Individuals who experience low levels of peer and teacher–student relations are more likely to use the Internet to compensate for lacking emotional peer and social relationships (Jia et al., 2017). Chang et al. (2019) concluded the Internet may be useful for developing interpersonal relationships without communicating fact-to-face. Individuals who are more anxious and neurotic about developing interpersonal relationships are more vulnerable to utilize the Internet problematically. Additionally, problematic Internet users are likely to have poor interpersonal relationships, subsequently inducing more loneliness (Moretta & Buodo, 2020); thus, problematic Internet use is associated with the breakdown of social relationships and a significant predictor of loneliness (Khazaei et al.,

2017, Koronczai et al., 2019). So lonely individuals may seek out the Internet to compensate for poor social relations, but if their use turns problematic loneliness is exacerbated.

In the current study, data obtained suggest the personality dimensions extraversion, agreeableness, conscientiousness, and emotional stability produced significant partial correlations with well-being. This finding is congruent with previous research by Volungis et al. (2019) who found these dimensions of personality were all negatively correlated with smartphone addictive behaviors thus, negatively affecting well-being. Furthermore, Kayış et al. (2016) carried out a meta-analysis investigating relations between Internet addiction and Big Five personality traits. Results propose all Big Five personality traits had a meaningful association with Internet addiction. Agreeableness, extraversion, openness, emotional stability, and conscientiousness were negatively related with Internet addiction thus, serving as protective factors for problematic Internet use.

Similarly, Koronczai et al. (2019) reported low conscientiousness and emotional stability negatively correlated with problematic Internet use. Researchers report low conscientiousness and emotional stability are not specific predictors of problematic Internet use, however, common in individuals diagnosed with psychopathologies such as depression. Koronczai reports low emotional stability indirectly affects problematic Internet use via psychological distress (e.g., depressive symptoms) whereas low conscientiousness directly affects problematic Internet use. Thus, psychopathological symptoms of depression are significant predictors of problematic Internet use. This is an important study as it suggests low conscientiousness and emotional instability may contribute to the maintenance of problematic Internet use.

Findings are limited in this study as it is correlational and cross sectional. Although this study shows an association between Internet use, personality, loneliness, and psychological well-being it does not demonstrate which is a causing factor. A longitudinal study would be required to verify. A strength of this study is that it adds to the existing research regarding problematic Internet use, loneliness, personality, and psychological well-being. This can inform future interventions in the development of treatment programmes to reduce problematic Internet use in society.

In relation to personality, attachment theory should be explored in a future study as research (Chang et al., 2019) suggests individuals with an insecure attachment tend to exhibit problematic Internet use. In comparison, securely attached people are less likely to develop an Internet addiction. Evidence of attachment could add to the existing research as to why people use the Internet problematically.

Problematic Internet use should be understood as a public health concern, globally as the findings of this study suggest problematic Internet use is significantly associated with a decline in well-being (World Health Organization, 2015). Furthermore, personality should be considered when developing interventions to prevent problematic Internet use as personality traits can be evaluated as both risk and protective factors. Kuss and Lopez-Fernandez (2016) suggest individuals may require help due to problematic Internet use as they cannot cope with their experiences; however, treatment of problematic Internet use has not yet been standardized (Khazaei et al., 2017). The positive psychology approach suggests the positive psychology interventions as a treatment for problematic Internet use. Positive psychology theory suggests that positive interventions improve well-being by directly and indirectly fostering positive thoughts, emotions, and behaviors. The goal is to reduce negative emotions and improve positive emotions subsequently, improving quality of life (Khazaei et al., 2017). Positive psychology focuses on human abilities such as pleasure, optimism, and happiness instead of focusing on human disabilities.

The Internet is used globally for connectivity; however, the nature of its use varies. Internet users are made up of different personality types with differing needs and motives

(Amichai-Hamburger & Ben-Artzi, 2003). This study suggests personality dimensions play a role in the process of developing problematic Internet use. This is important when considering psychopathologies as individuals prone to mental health problems are more likely to avoid face-to-face communication, becoming dependent on online interactions leading to an increased risk of further loneliness and problematic Internet use.

### ACKNOWLEDGMENTS

We will make data, analytic methods (code), and study materials available to other researchers on request to the first author. This study was not preregistered.

### FUNDING INFORMATION

There was no funding or external support for the work reported in this paper.

### CONFLICT OF INTEREST

The authors have no conflicts of interest.

### ETHICAL APPROVAL

The study was approved by the School of Psychology Ethics Committee.

### ORCID

Tony Cassidy  <https://orcid.org/0000-0003-0547-6086>

### REFERENCES

- Amichai-Hamburger, Y. & Ben-Artzi, E. (2003) Loneliness and internet use. *Computers in Human Behavior*, 19(1), 71–80. [https://doi.org/10.1016/s0747-5632\(02\)00014-6](https://doi.org/10.1016/s0747-5632(02)00014-6)
- Apaolaza, V., Hartmann, P., Medina, E., Barrutia, J. & Echebarria, C. (2013) The relationship between socializing on the Spanish online networking site Tuenti and teenagers' subjective wellbeing: The roles of self-esteem and loneliness. *Computers in Human Behavior*, 29(4), 1282–1289. <https://doi.org/10.1016/j.chb.2013.01.002>
- Blonigen, D.M., Carlson, M.D., Hicks, B.M., Krueger, R.F. & Iacono, W.G. (2008) Stability and change in personality traits from late adolescence to early adulthood: A longitudinal twin study. *Journal of Personality*, 76(2), 229–266
- Branje, S., Vam Lieshout, C.F.M. & Gerris, R.M. (2007) Big Five personality development in adolescence and adulthood. *European Journal of Personality*, 21(1), 45–62
- Çevik, G.B. & Yildiz, M.A. (2017) The roles of perceived social support, coping, and loneliness in predicting internet addiction in adolescents. *Journal of Education and Practice*, 8(12), 64–73.
- Chang, Y., Lee, Y. & Hsieh, S. (2019) Internet interpersonal connection mediates the association between personality and internet addiction. *International Journal of Environmental Research and Public Health*, 16(19), 3537. <https://doi.org/10.3390/ijerph16193537>
- Chou, C., Condrón, L. & Belland, J.C. (2005) A review of the research on internet addiction. *Educ Psychological Review*, 17, 363–388. <https://doi.org/10.1007/s10648-005-8138-1>
- Davis, R., Flett, G. & Besser, A. (2002) Validation of a new scale for measuring problematic internet use: Implications for pre-employment screening. *Cyberpsychology & Behavior*, 5(4), 331–345. <https://doi.org/10.1089/109493102760275581>
- Gosling, S.D., Rentfrow, P.J. & Swann, W.B., Jr. (2003) A very brief measure of the Big-Five personality domains. *Journal of Research in Personality*, 37, 504–528.
- Jackson, L.A., von Eye, A., Biocca, F.A., Barbatsis, G., Fitzgerald, H.E. & Zhao, Y. (2003) Personality, cognitive style, demographic characteristics and Internet use—Findings from the HomeNetToo project. *Swiss Journal of Psychology / Schweizerische Zeitschrift für Psychologie / Revue Suisse de Psychologie*, 62(2), 79–90. <https://doi.org/10.1024/1421-0185.62.2.79>

- Jia, J., Li, D., Li, X., Zhou, Y., Wang, Y. & Sun, W. (2017) Psychological security and deviant peer affiliation as mediators between teacher-student relationship and adolescent Internet addiction. *Computers in Human Behavior*, 73, 345–352. <https://doi.org/10.1016/j.chb.2017.03.063>
- Jobe, L.E. & White, S.W. (2007) Loneliness, social relationships, and a broader autism phenotype in college students. *Personality and Individual Differences*, 42(8), 1479–1489
- Kayış, A., Satici, S., Yilmaz, M., Şimşek, D., Ceyhan, E. & Bakioglu, F. (2016) Big five-personality trait and internet addiction: A meta-analytic review. *Computers in Human Behavior*, 63, 35–40. <https://doi.org/10.1016/j.chb.2016.05.012>
- Khazaei, F., Khazaei, O. & Ghanbari-H., B. (2017) Positive psychology interventions for internet addiction treatment. *Computers in Human Behavior*, 72, 304–311. <https://doi.org/10.1016/j.chb.2017.02.065>
- Koronczi, B., Kökönyei, G., Griffiths, M. & Demetrovics, Z. (2019) The relationship between personality traits, psychopathological symptoms, and problematic internet use: A complex mediation model. *Journal of Medical Internet Research*, 21(4), e11837. <https://doi.org/10.2196/11837>
- Kuss, D.J. & Lopez-Fernandez, O. (2016) Internet addiction and problematic Internet use: A systematic review of clinical research. *World Journal of Psychiatry*, 6(1), 143–176 <https://doi.org/10.5498/wjp.v6.i1.143>
- Kuss, D.J., Griffiths, M.D., Karila, L. & Billieux, J. (2014) Internet addiction: A systematic review of epidemiological research for the last decade. *Current Pharmaceutical Design*, 20, 4026–4052 [PMID: 24001297] <https://doi.org/10.2174/13816128113199990617>
- Laconi, S., Kaliszewska-Czeremska, K., Gnisci, A., Sergi, I., Barke, A., Jeromin, F., ... Kuss, D.J. (2018) Cross-cultural study of Problematic Internet Use in nine European countries. *Computers in Human Behavior*, 84, 430–440. <https://doi.org/10.1016/j.chb.2018.03.020>
- Lobel, A., Engels, R.C.M.E., Stone, L.L., Burk, W.J. & Granic, I. (2017) Video gaming and children's psychosocial wellbeing: A longitudinal study. *Journal of Youth and Adolescence*, 46, 884–897. <https://doi.org/10.1007/s10964-017-0646-z>
- Marchant, A., Hawton, K., Stewart, A., Montgomery, P., Singaravelu, V., Lloyd, K., ... John, A. (2017) A systematic review of the relationship between internet use, self-harm and suicidal behaviour in young people: The good, the bad and the unknown. *PLoS ONE*, 12(8), e0181722. <https://doi.org/10.1371/journal.pone.0181722>
- Moretta, T. & Buodo, G. (2020) Problematic internet use and loneliness: How complex is the relationship? A short literature review. *Current Addiction Reports*, 7, 125–136. <https://doi.org/10.1007/s40429-020-00305-z>
- Muusses, L., Finkenauer, C., Kerkhof, P. & Billede, C. (2014) A longitudinal study of the association between Compulsive Internet use and wellbeing. *Computers in Human Behavior*, 36, 21–28. <https://doi.org/10.1016/j.chb.2014.03.035>
- Nowland, R., Necka, E. & Cacioppo, J. (2017) Loneliness and social internet use: Pathways to reconnection in a digital world? *Perspectives on Psychological Science*, 13(1), 70–87. <https://doi.org/10.1177/1745691617713052>
- Pallavicini, F., Ferrari, A. & Mantovani, F. (2018) Video games for well-being: A systematic review on the application of computer games for cognitive and emotional training in the adult population. *Frontiers in Psychology*, 9, 2127. <https://doi.org/10.3389/fpsyg.2018.02127>
- Przepiorka, A., Blachnio, A., Miziak, B. & Czuczwar, S. (2014) Clinical approaches to treatment of Internet addiction. *Pharmacological Reports*, 66(2), 187–191. <https://doi.org/10.1016/j.pharep.2013.10.001>
- Robins, R.W., Fraley, R.C., Roberts, B.W. & Trzesniewski, K.H. (2001) A longitudinal study of personality change in young adulthood. *Journal of Personality*, 69, 617–640. <https://doi.org/10.1111/1467-6494.694157>
- Russell, D., Peplau, L. & Cutrona, C. (1980) The revised UCLA Loneliness Scale: Concurrent and discriminant validity evidence. *Journal of Personality and Social Psychology*, 39(3), 472–480. <https://doi.org/10.1037/0022-3514.39.3.472>
- Shapira, N., Lessig, M., Goldsmith, T., Szabo, S., Lazoritz, M., Gold, M. & Stein, D.J. (2003) Problematic internet use: Proposed classification and diagnostic criteria. *Depression and Anxiety*, 17(4), 207–216. <https://doi.org/10.1002/da.10094>
- Shi, M. & Du, T.J. (2019) Associations of personality traits with internet addiction in Chinese medical students: The mediating role of attention-deficit/hyperactivity disorder symptoms. *BMC Psychiatry*, 19, 183. <https://doi.org/10.1186/s12888-019-2173-9>
- Singh Balhara, Y., Singh, S. & Bhargava, R. (2019) The pattern of problematic internet use and mental health-related internet use among psychiatric outpatients at a tertiary care center. *Tzu Chi Medical Journal*, 32(2), 198–204. [https://doi.org/10.4103/tcmj.tcmj\\_50\\_19](https://doi.org/10.4103/tcmj.tcmj_50_19)

- Tennant, R., Hiller, L., Fishwick, R., Platt, S., Joseph, S., Weich, S., ... Stewart-Brown, S. (2007) The Warwick-Edinburgh mental well-being scale (WEMWBS): Development and UK validation. *Health and Quality of Life Outcomes*, 5(1), 63. <https://doi.org/10.1186/1477-7525-5-63>
- Thorens, G., Achab, S., Billieux, J., Khazaal, Y., Khan, R., Pivin, E., ... Zullino, D. (2014) Characteristics and treatment response of self-identified problematic Internet users in a behavioral addiction outpatient clinic. *Journal of Behavioural Addiction*, 3, 78–81 [PMID: 25215217] <https://doi.org/10.1556/JBA.3.2014.008>
- Tian, Z., Liu, F., Li, Z., Malekian, R., & Xie, Y. (2017). The Development of Key Technologies in Applications of Vessels Connected to the Internet. *Symmetry*, 9, 211; <https://doi.org/10.3390/sym9100211>
- Volungis, A.M., Kalpidou, M., Popores, C. & Joyce, M. (2019) Smartphone addiction and its relationship with indices of social-emotional distress and personality. *International Journal of Mental Health and Addiction*, 18, 1–17.
- Van Dijk, M.P.A., Hale, W.W., Hawk, S.T., Meeus, W. & Branje, S. (2020) Personality development from age 12 to 25 and its links with life transitions. *European Journal of Personality*, 34(3), 322–344. <https://doi.org/10.1002/per.2251>
- Winkler, A., Dörsing, B., Rief, W., Shen, Y. & Glombiewski, J.A. (2013) Treatment of internet addiction: A meta-analysis. *Clinical Psychology Review*, 33, 317–329 [PMID: 23354007] <https://doi.org/10.1016/j.cpr.2012.12.005>
- World Health Organization. (2015) *Public health implications of excessive use of the internet, computers, smartphones and similar electronic devices*: Meeting report, Main Meeting Hall, Foundation for Promotion of Cancer Research, National Cancer Research Centre, Tokyo, Japan, 27–29 August 2014. World Health Organization. <https://apps.who.int/iris/handle/10665/184264>

## AUTHOR BIOGRAPHIES

**Tony Cassidy** is a professor of Child and Family Health Psychology at Ulster University in Northern Ireland.

**Francesca Dalton** is a postgraduate student in the School of Psychology at Ulster University, Northern Ireland.

**How to cite this article:** Dalton F, Cassidy T. Problematic Internet usage, personality, loneliness and psychological well-being in emerging adulthood. *Analyses of Social Issues and Public Policy*. 2021;21:509–519. <https://doi.org/10.1111/asap.12224>

Copyright of *Analyses of Social Issues & Public Policy* is the property of Wiley-Blackwell and its content may not be copied or emailed to multiple sites or posted to a listserv without the copyright holder's express written permission. However, users may print, download, or email articles for individual use.